

**Now available with
MVD™ Technology!**

ELITE® Mass Flow and Density Meters



MVD™ technology



Micro Motion
FISHER-ROSEMOUNT™

Micro Motion® ELITE® Meters

Experience the most accurate Coriolis meters available today.

Micro Motion® ELITE® meters are the leading flowmeter for precision flow measurement. And with good reason. ELITE meters offer the most accurate measurement available for virtually any process fluid, while exhibiting exceptionally low pressure drop.

Seven sizes of ELITE meters offer direct mass flow, volume flow, density, and temperature measurement of liquids, gases, and slurries — without the need for additional equipment, manual calculations or estimations.

Micro Motion ELITE meters are designed for unsurpassed performance in even the most harsh operating environments. They have no moving parts, and no special mounting or flow conditioning requirements. Every ELITE meter features standard secondary containment, and is available with stainless steel or nickel alloy wetted parts and a wide variety of process connections to meet your every need. And, they require no maintenance — saving you money over the course of their lifetime by helping you make the most of your time, people, and materials.

ELITE meters carry hazardous area approvals for the U.S.A. and Canada, Europe, Australia, Japan and other areas in the Asia-Pacific region.

Special Applications

Several ELITE meters have been designed for special applications. The CMF010 is our smallest meter, designed for remarkably high performance in low-flow applications. It features a single, continuous flow tube, and is also available in a high-pressure model, for applications up to 6000 psi (413 bar).

Much larger in size is our CMF400. This 4-inch meter offers the most accurate measurement available in a high-capacity meter.

The 3-inch CMF300A is a high-temperature meter. It provides the same accuracy and measurement capabilities as our other ELITE meters, at temperatures up to 650°F (343°C).

Our CMF025, CMF050, and CMF100 meters are available with optional, flangeless, wafer-style process connections.

MVD™ Technology

Micro Motion ELITE meters are now available with MVD™ Technology — a new, innovative, multivariable, digital signal processing capability. A core processor, integrally mounted on the ELITE sensor, works with our new Series 1000 and 2000 transmitters to improve ease of use, reduce downtime, and lower your flow metering costs. Meters with MVD Technology provide cleaner, noise-free digital signals. Digital signal processing means faster response times, enhanced diagnostic capabilities, higher accuracy, and better repeatability.

System Integration

Micro Motion offers a variety of microprocessor-based transmitters, any of which can be connected to our ELITE sensors. Depending on the transmitter model, features include milliampere and frequency/pulse outputs, transmitter and process control functions in a single device, and API outputs for crude oil and other hydrocarbon fluids.

Other options include transmitters that can be installed in instrument racks or panels, or housed in NEMA or explosion-proof enclosures. Sensors and explosion-proof transmitters can be installed in the same hazardous area.

Micro Motion ELITE meters can be installed as part of a Bell 202 multidrop network, an RS-485 digital communications network, or a Profibus-PA or FOUNDATION™ fieldbus system.

Transmitters feature HART®, Modbus®, FOUNDATION™ fieldbus, Profibus-PA, and other communication protocols. And all our transmitters support Fisher-Rosemount™ PlantWeb® field-based architecture, which uses the power of intelligent, interoperable field devices to improve plant performance.

Micro Motion is known worldwide for increasing plant efficiency, production, and profitability. More than 300,000 Micro Motion meters are installed and working in processes just like yours. Contact us, and discover the best precision flowmeters available today — Micro Motion ELITE meters.

Performance specifications

Liquid Flow		Mass		Volume	
Nominal flow range⁽¹⁾		lb/min	kg/h	gal/min	l/h
	CMF010	0 to 3	0 to 82	0 to 0.4	0 to 82
	CMF025	0 to 40	0 to 1090	0 to 5	0 to 1090
	CMF050	0 to 125	0 to 3400	0 to 15	0 to 3400
	CMF100	0 to 500	0 to 13,600	0 to 60	0 to 13,600
	CMF200	0 to 1600	0 to 43,550	0 to 192	0 to 43,550
	CMF300	0 to 5000	0 to 136,080	0 to 600	0 to 136,080
	CMF400	0 to 15,000	0 to 409,000	0 to 1800	0 to 409,000
Maximum flow rate		lb/min	kg/h	gal/min	l/h
	CMF010	4	108	0.4	108
	CMF025	80	2180	10	2180
	CMF050	250	6800	30	6800
	CMF100	1000	27,200	120	27,200
	CMF200	3200	87,100	385	87,100
	CMF300	10,000	272,160	1200	272,160
	CMF400	20,000	545,500	2400	545,500
Mass Flow Accuracy⁽²⁾	1700/2700 transmitter or direct host	±0.10% of rate ⁽³⁾			
	All other transmitters	±0.10% ± [(zero stability/ flow rate) x 100]% of rate			
Mass Flow Repeatability⁽²⁾	1700/2700 transmitter or direct host	±0.05% of rate ⁽³⁾			
	All other transmitters	±0.05% ± [½(zero stability/flow rate) x 100]% of rate			
Zero stability		lb/min	kg/h		
	CMF010	0.000075	0.002		
	High-pressure CMF010P	0.00015	0.004		
	CMF025	0.001	0.027		
	CMF050	0.006	0.163		
	CMF100	0.025	0.680		
	CMF200	0.08	2.18		
	CMF300	0.25	6.80		
	CMF400	1.50	40.91		

⁽¹⁾ Micro Motion has adopted the terminology "nominal flow range." The upper limit of this range is the flow rate at which water at reference conditions causes approximately 15 psid (1 bar) of pressure drop for ELITE sensors.

⁽²⁾ Accuracy includes the combined effects of repeatability, linearity, and hysteresis. All specifications for liquids are based on reference conditions of water at 68 to 77°F (20 to 25°C) and 15 to 30 psig (1 to 2 bar), unless otherwise noted.

⁽³⁾ When flow rate is less than (zero stability/0.001), accuracy equals ±[(zero stability/flow rate) x 100]% of rate and repeatability equals ±[½(zero stability/flow rate x 100)% of rate.

Performance specifications *continued*

Gas Flow		Standard Volume⁽¹⁾	
Nominal flow range⁽²⁾		scfm	Nm³/h
	CMF010	0 to 15	0 to 25
	CMF025	0 to 205	0 to 355
	CMF050	0 to 535	0 to 870
	CMF100	0 to 2375	0 to 3865
	CMF200	0 to 7145	0 to 11,600
	CMF300	0 to 23,700	0 to 38,670
Maximum flow rate		scfm	Nm³/h
	CMF010	30	50
	CMF025	390	630
	CMF050	1000	1615
	CMF100	4400	7100
	CMF200	13,400	21,630
	CMF300	44,000	71,000
Mass Flow Accuracy⁽³⁾	1700/2700 transmitter or direct host	±0.35% of rate ⁽⁴⁾	
	All other transmitters	±0.50% ± [(zero stability/ flow rate) x 100]% of rate	
Mass Flow Repeatability⁽³⁾	1700/2700 transmitter or direct host	±0.20% of rate ⁽⁴⁾	
	All other transmitters	±0.25% ± [(zero stability/ flow rate) x 100]% of rate	
Zero stability		scfm	Nm³/h
	CMF010	0.0010	0.0015
	High-pressure CMF010P	0.0020	0.003
	CMF025	0.0131	0.021
	CMF050	0.0784	0.126
	CMF100	0.3265	0.526
	CMF200	1.045	1.69
	CMF300	3.265	5.26

⁽¹⁾ Air density at standard conditions, 14.73 psia, 60 °F, equals 0.077 lb/ft³ for scfm. For Nm³/h, normal conditions are 1.013 bara, 0 °C equals 1.293 kg/m³.

⁽²⁾ Micro Motion has adopted the terminology "nominal flow range." The upper limit of this range is the flow rate at which air at 60 °F (15.5 °C) and 1000 psig (70 bar) causes approximately 15 psid (1 bar) of pressure drop for ELITE sensors.

⁽³⁾ Accuracy includes the combined effects of repeatability, linearity, and hysteresis. All specifications for gas are based on air at 60 °F (15.5 °C) and 1000 psig (70 bar), unless otherwise noted.

⁽⁴⁾ When flow rate is less than (zero stability/0.0035), accuracy equals ±[(zero stability/flow rate) x 100]% of rate, and repeatability is equal to ±[½(zero stability/flow rate) x 100]% of rate.

Performance specifications *continued*

			with Model 2700, 3500, 3700, RFT9739, 5300, or RFT9709 transmitter		with IFT9701 transmitter	
			<i>g/cc</i>	<i>kg/m³</i>	<i>g/cc</i>	<i>kg/m³</i>
Density	High-pressure CMF010P	liquid	±0.002	±2.0	±0.008	±8.0
	All other models	liquid	±0.0005	±0.5	±0.002	±2.0
Accuracy⁽¹⁾	High-pressure CMF010P	liquid	±0.001	±1.0	±0.004	±4.0
	All other models	liquid	±0.0002	±0.2	±0.001	±1.0
Repeatability⁽¹⁾	All models		0 to 5	0 to 5000	0 to 5	0 to 5000
Range						
Temperature						
Accuracy	All models		±1 °C ± 0.5% of reading in °C			
Repeatability	All models		±0.2 °C			
Range⁽²⁾	CMF010, CMF025, CMF050, CMF100, CMF200, CMF300M, CMF300H ⁽³⁾⁽⁴⁾	with core processor	°F	°C		
			-60 to 257	-50 to 125	process fluid	
	High-temperature CMF300A ⁽³⁾	with junction box	-400 to 400	-240 to 204	process fluid	
		sensor	32 to 650	0 to 343	process fluid	
	CMF400 ⁽⁵⁾	junction box	-40 to 248	-40 to 120	ambient	
		with integral booster amplifier	-40 to 140	-40 to 60	process fluid	
with remote booster amplifier		-400 to 400	-240 to 204	process fluid		
Remote booster amplifier for CMF400		-40 to 140	-40 to 60	ambient		

⁽¹⁾ Accuracy includes the combined effects of repeatability, linearity, and hysteresis. All specifications for liquids are based on reference conditions of water at 68 to 77 °F (20 to 25 °C) and 15 to 30 psig (1 to 2 bar), unless otherwise noted.

⁽²⁾ For CENELEC-compliant sensors, the CENELEC "T" rating and hazardous area classification depend on the maximum process fluid and ambient temperature. See page 11.

⁽³⁾ For CENELEC-compliant sensors, the maximum ambient temperature is 55 °C. Use of sensors with a junction box above 55 °C is acceptable, provided the ambient temperature does not exceed the CENELEC "T" rating listed on page 11 for temperature of the fluid.

⁽⁴⁾ For CENELEC-compliant sensors, the minimum process fluid and ambient temperature is -20 °C. If the process fluid remains at or above 0 °C, ambient temperature below -20 °C is acceptable for sensors with a junction box, and ambient temperature of -40 °C is allowed for sensors with a core processor.

⁽⁵⁾ For CENELEC-compliant sensors, the maximum ambient temperature is 60 °C and the minimum ambient temperature is -40 °C.

Performance specifications *continued*

Pressure ratings

Flow tube rating⁽¹⁾		
	psi	bar
Stainless steel sensors	1450	100
Nickel alloy sensors	2160	148
High-pressure CMF010P	6000	413
Housing rating⁽¹⁾		
	psi	bar
CMF010 ⁽²⁾	470	32
CMF025	900	62
CMF050	930	64
CMF100	730	50
CMF200	550	38
CMF300	275	18
CMF400	250	17
Short-term housing rating⁽¹⁾⁽³⁾		
	psi	bar
CMF010 ⁽²⁾	625	43
CMF025	1200	82
CMF050	1240	85
CMF100	970	66
CMF200	730	50
CMF300	365	25
CMF400	325	22

⁽¹⁾ Pressure ratings at 77°F (25°C), according to ASME B31.3. For higher operating temperatures, pressure needs to be derated as follows:

		Flow tubes 316L sensors	Flow tubes nickel alloy sensors	Housing all sensors
All sensors	201 to 300°F (94 to 148°C)	none	2% derating	none
	301 to 400°F (149 to 204°C)	7.2% derating	9.2% derating	7.2% derating
High-temperature CMF300A	401 to 500°F (205 to 260°C)	13.8% derating	not applicable	11.4% derating
	501 to 600°F (261 to 316°C)	19.2% derating	not applicable	16.2% derating
	601 to 650°F (317 to 343°C)	20.1% derating	not applicable	18.0% derating

⁽²⁾ Optional rupture disks for high-pressure CMF010 will burst if pressure inside sensor housing reaches 400 psi (27 bar).

⁽³⁾ Housing pressure rating for 10 hours or less, according to ASME B31.3.

Performance specifications *continued*

Typical accuracy, turndown, and pressure drop with 1700/2700 transmitter or direct host⁽¹⁾

CMF010N
CMF010M
CMF025

Turndown	500:1	100:1	20:1	10:1	1:1
Accuracy (±%)					
liquid	1.25	0.25	0.10	0.10	0.10
gas	1.25	0.35	0.35	0.35	0.35
Pressure drop					
liquid (psi)	~0	~0	0.1	0.2	14.5
liquid (bar)	~0	~0	0.01	0.01	1.0
gas (psi)	0	0	0	0.2	13.8
gas (bar)	0	0	0	0.01	0.88

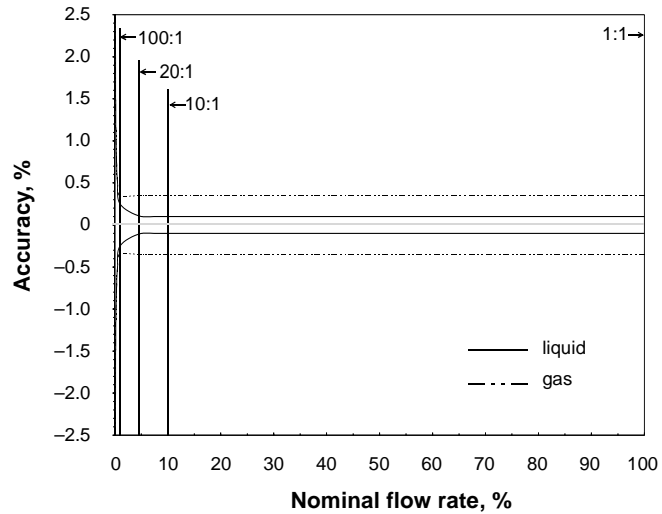

CMF010P
CMF050
CMF100
CMF200
CMF300

Turndown	500:1	100:1	20:1	10:1	1:1
Accuracy (±%)					
liquid	2.50	0.50	0.10	0.10	0.10
gas	2.50	0.50	0.35	0.35	0.35
Pressure drop					
liquid (psi)	~0	~0	0.1	0.2	13.5
liquid (bar)	~0	~0	0.01	0.01	0.93
gas (psi)	0	0	0.1	0.3	14.1
gas (bar)	0	0	0.01	0.02	0.97

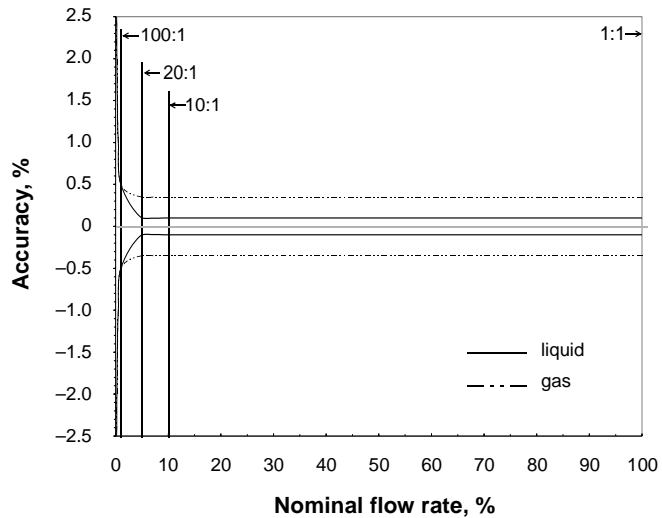

⁽¹⁾ To determine accuracy, turndown, and pressure drop using your process variables, or contact your local Micro Motion representative.

Performance specifications *continued*

Typical accuracy, turndown, and pressure drop with 1700/2700 transmitter or direct host⁽¹⁾

CMF400

Turndown	500:1	100:1	20:1	10:1	1:1
Accuracy (±%)					
liquid	5	1.0	0.20	0.10	0.10
Pressure drop					
liquid (psi)	~0	~0	~0	0.2	14.1
liquid (bar)	~0	~0	<0.01	0.01	1.0

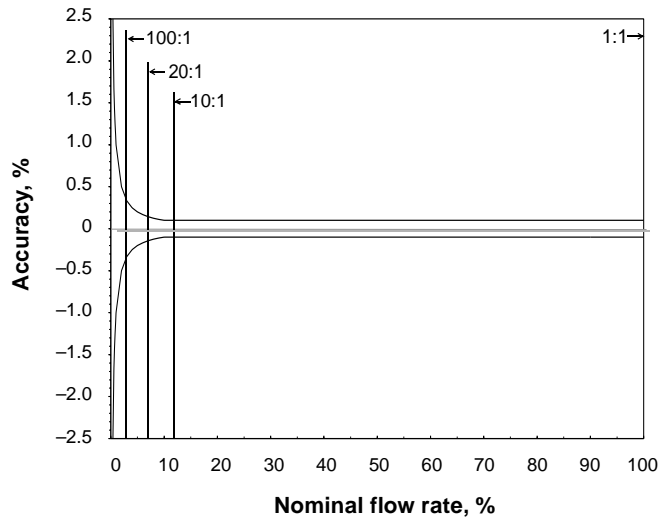

⁽¹⁾ To determine accuracy, turndown, and pressure drop using your process variables, or contact your local Micro Motion representative.

Functional specifications

Environmental effects

Process temperature effect Process temperature effect is defined as the worst-case zero offset due to process fluid temperature change away from the zeroing temperature for flow rate and calibration temperature for density.

Process temperature effect

	<i>% of nominal flow rate per °C⁽¹⁾</i>	<i>density accuracy per °C</i>
CMF010	±0.00025	±0.000015 g/cc
CMF025	±0.00025	±0.000015 g/cc
CMF050	±0.00025	±0.000015 g/cc
CMF100	±0.00025	±0.000015 g/cc
CMF200	±0.001	±0.000015 g/cc
CMF300	±0.001	±0.000015 g/cc
CMF400	±0.001	±0.000015 g/cc

Pressure effect Pressure effect is defined as the change in sensor flow due to process pressure change away from the calibration pressure. Pressure effect can be corrected.

Pressure effect on flow accuracy

	<i>% of rate per psi</i>	<i>% of rate per bar</i>
CMF010	none	none
CMF025	none	none
CMF050	none	none
CMF100	-0.0002	-0.003
CMF200	-0.0008	-0.012
CMF300	-0.0006	-0.009
CMF400	-0.002	-0.029

⁽¹⁾ Nominal flow rate is the upper limit of the nominal flow range.

Functional specifications *continued*

Hazardous area classifications

UL is a U.S.A. approvals agency, CSA is a Canadian approvals agency that provides approvals accepted both in the U.S.A. and in Canada. CENELEC is a European standards organization, and SAA is an Australian approvals agency.

UL and CSA
 Class I, Div. 1, Groups C and D
 Class I, Div. 2, Groups A, B, C, and D
 Class II, Div.1, Groups E, F, and G

SAA

CMF025	Ex ib IIC T5
CMF050	Ex ib IIC T5
CMF100	Ex ib IIC T6
CMF200	Ex ib IIB T6
CMF300 ⁽¹⁾	Ex ib IIB T6

CENELEC⁽²⁾

**sensors with core processor
 except CMF400**

CMF010, CMF025, CMF050, CMF100
 EEx ib IIC T1...T5
 CMF200, CMF300
 EEx ib IIB T1...T5

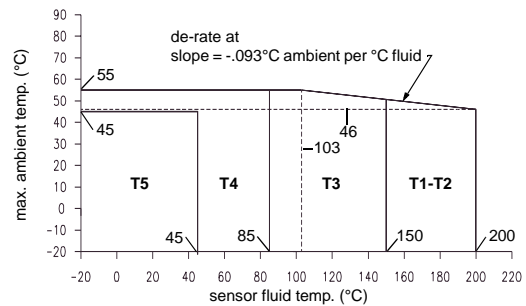

**sensors with junction box,
 except CMF300A and CMF400**

CMF010, CMF025, CMF050, CMF100
 EEx ib IIC T1...T6
 CMF200, CMF300
 EEx ib IIB T1...T6

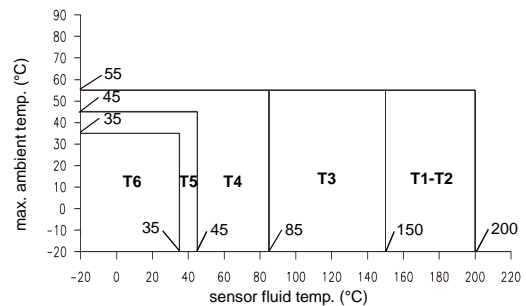

CMF300A

EEx ib IIB T1...T6

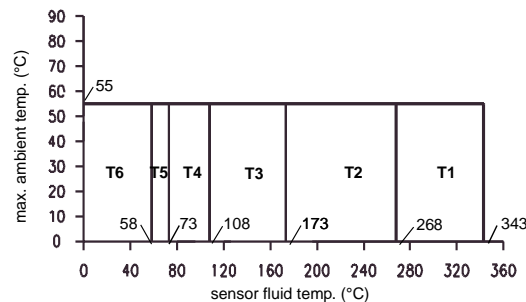

⁽¹⁾ Standard-temperature model only. CMF300A high-temperature model is not SAA approved.

⁽²⁾ CENELEC "T" rating depends on the maximum temperature shown in the graphs above. Ambient temperature limits are -20°C and 55°C for all sensors except CMF400. CMF400 ambient temperature limits are -40°C to 60°C .

Functional specifications *continued*

Hazardous area classifications *continued*

CENELEC⁽¹⁾

CMF400 with integral booster amplifier and integral core processor

EEx de[ib] ibIIB T1...T5

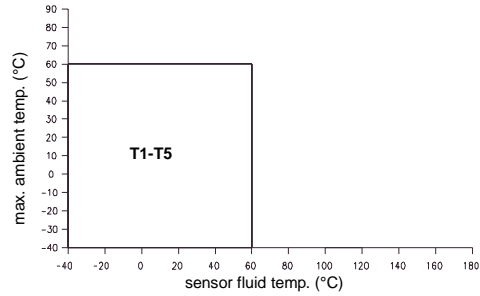

CMF400 with integral booster amplifier and junction box

EEx de[ib] ibIIB T1...T6

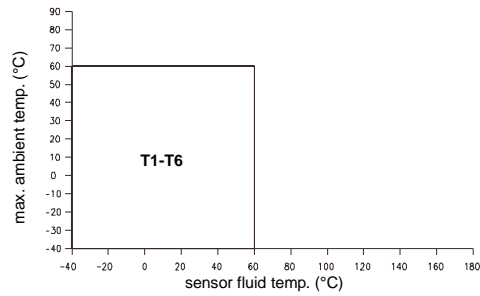

CMF400 with remote booster amplifier

EEx de[ib] ibIIB T1...T6

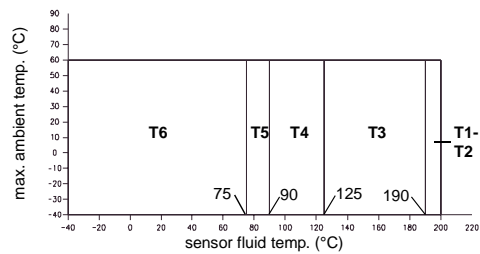

⁽¹⁾ CENELEC "T" rating depends on the maximum temperature shown in the graphs above. Ambient temperature limits are -20°C and 55°C for all sensors except CMF400. CMF400 ambient temperature limits are -40°C to 60°C.

Physical specifications

Materials of construction

Wetted parts⁽¹⁾		Stainless steel	Nickel alloy
	CMF010	316L	Inconel® alloy 686
	CMF025	316L	Hastelloy® C-22
	CMF050	316L	Hastelloy C-22
	CMF100	316L	Hastelloy C-22
	CMF200	316L	Hastelloy C-22
	CMF300	316L	Hastelloy C-22
	High-temperature CMF300A	316L	not available
	CMF400	316L	not available
Housing	304L stainless steel		
Junction box	Epoxy-coated aluminum		
Core processor <i>not available with CMF300A</i>	316L stainless steel		
Booster amplifier housing (for CMF400 only)	Epoxy-coated aluminum		

Weight⁽²⁾

	With junction box		With core processor	
	lb	kg	lb	kg
CMF010	14	7	17	8
CMF025	8	4	11	5
CMF050	12	6	15	7
CMF100	29	13	32	15
CMF200	63	29	66	30
CMF300	165	75	168	76
CMF400 with integral booster amplifier	432	196	435	197
CMF400 with remote booster amplifier (sensor only)	438	198	438	198
Remote booster amplifier	13	6	15	7

⁽¹⁾ General corrosion guides do not account for cyclical stress, and therefore should not be relied upon when choosing a wetted material for your Micro Motion sensor. Please refer to Micro Motion's corrosion guide for proper material compatibility information.

⁽²⁾ Weight of sensor with ANSI 150 lb weld neck raised face flanges.

CMF010 dimensions and process fittings

Dimensions in inches (mm)

CMF010 with core processor

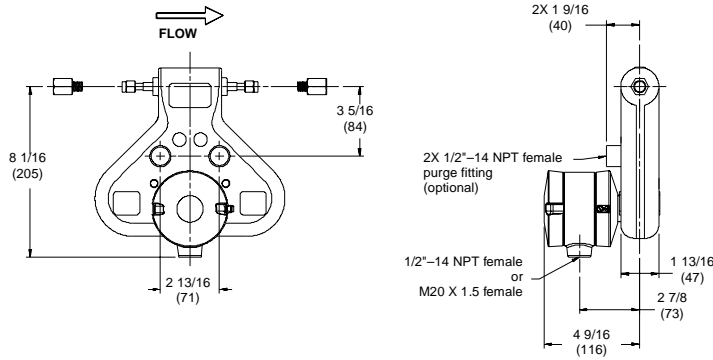

Union fitting

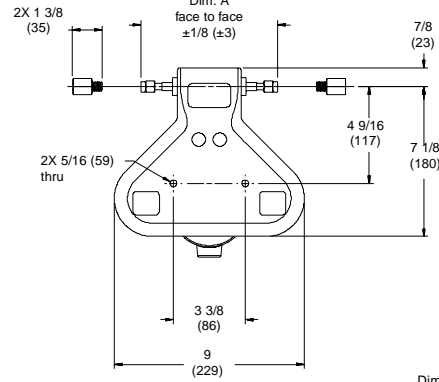

CMF010 with junction box

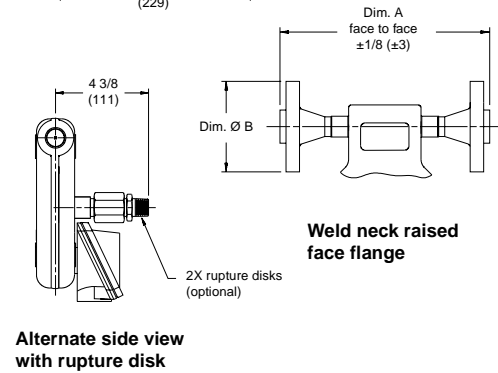
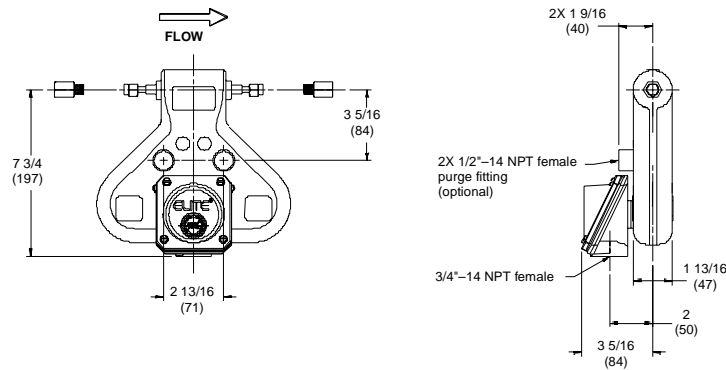

Fittings for stainless steel sensors ⁽¹⁾	Fitting code	Dim. A Face-to-face	Dim. B Outside diam.
1/2-inch 150 lb ANSI weld neck raised face flange	313	7 7/8 (199)	3 1/2 (89)
1/2-inch 300 lb ANSI weld neck raised face flange	314	8 3/16 (209)	3 3/4 (95)
1/2-inch 600 lb ANSI weld neck raised face flange	315	8 11/16 (221)	3 3/4 (95)
1/2-inch sanitary fitting	321	6 15/16 (177)	1 (25)
15 mm DIN PN40 weld neck, DIN 2635, type C face	300	7 7/16 (189)	3 3/4 (95)
15 mm DIN PN100 weld neck, DIN 2637, type E face	302	8 (203)	4 1/8 (105)
15mm JIS 10K weld neck	304	7 3/16 (183)	3 3/4 (95)
15 mm JIS 20K weld neck	305	7 3/16 (183)	3 3/4 (95)
1/4-inch NPT female union fitting	323	6 7/16 (164)	---
1/4-inch tube compression fitting	324	6 7/16 (164)	---
6 mm tube compression fitting	325	6 7/16 (164)	---
Fittings for nickel alloy sensors⁽¹⁾			
1/2-inch 150 lb ANSI lap joint flange	520	7 7/8 (199)	3 1/2 (89)
1/2-inch 300 lb ANSI lap joint flange	521	8 3/16 (209)	3 3/4 (95)
15 mm DIN PN40 lap joint, DIN 2656	523	9 7/16 (240)	3 3/4 (95)
15 mm JIS 10K lap joint flange	522	8 3/16 (208)	3 3/4 (95)
1/4-inch NPT female union fitting	323	6 7/16 (164)	---
Fittings for high-pressure sensors⁽¹⁾			
1/4-inch NPT female union fitting	323	6 7/16 (164)	---
1/4-inch tube compression fitting	324	6 7/16 (164)	---
6 mm tube compression fitting	325	6 7/16 (164)	---

⁽¹⁾ Fittings listed here are standard options. Other types of fittings are available. Contact your local Micro Motion representative.

CMF025 dimensions and process fittings

Dimensions in inches
(mm)

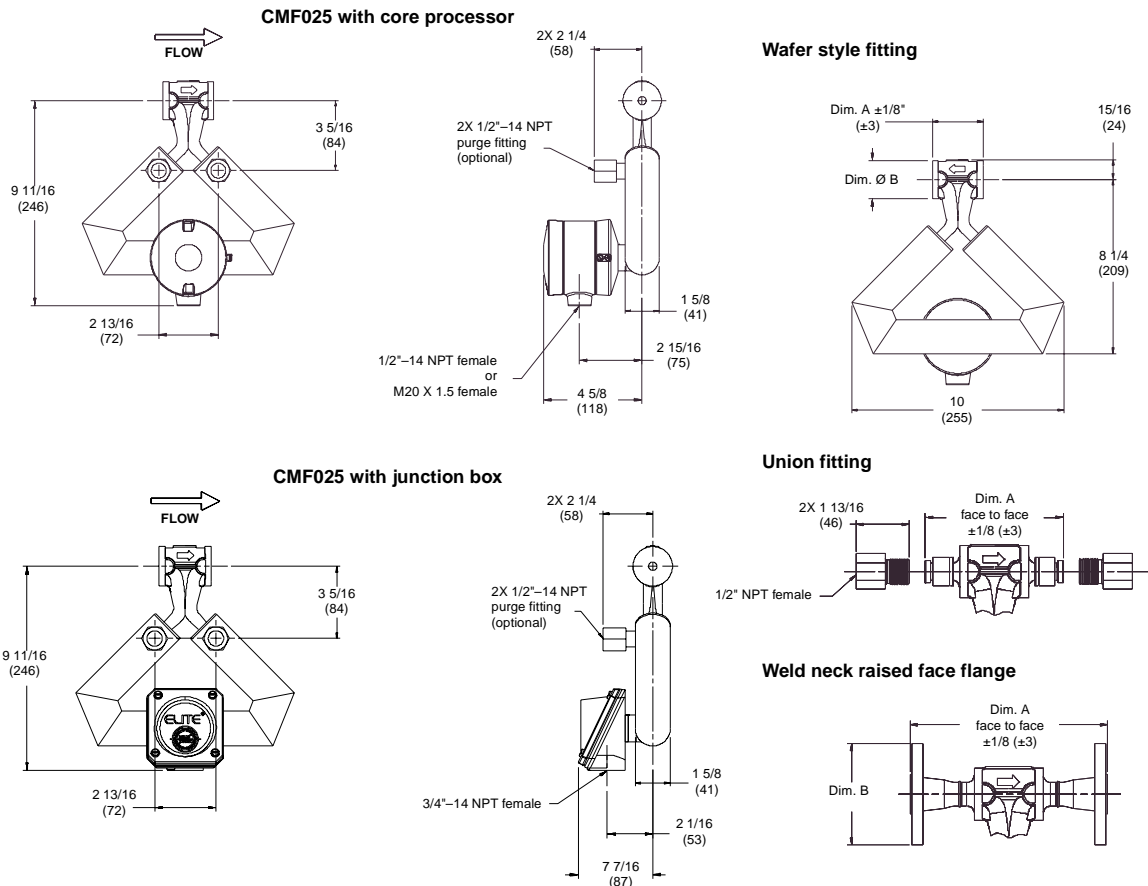

Fittings for stainless steel sensors ⁽¹⁾	Fitting code	Dim. A Face-to-face	Dim. B Outside diam.
Wafer style, 1/2" ANSI (150 lb, 300 lb, 600 lb bolt kit)	009	2 3/8 (60)	1 13/16 (46)
Wafer style, 15 mm DIN 2635, type C facing (PN40 bolt kit)	016	2 3/8 (60)	1 13/16 (46)
Wafer style, 15 mm DIN 2635, type N grooved facing (PN40 bolt kit)	017	2 3/8 (60)	1 13/16 (46)
Wafer style, 15 mm DIN 2637, type E facing (PN100 bolt kit)	018	2 3/8 (60)	1 13/16 (46)
Wafer style, 15 mm DIN 2637, type N grooved facing (PN100 bolt kit)	019	2 3/8 (60)	1 13/16 (46)
Wafer style, 15 mm, standard JIS facing (10K, 20K bolt kit)	029	2 3/8 (60)	1 13/16 (46)
1/2" ANSI 150 lb weld neck raised face flange	313	6 3/4 (172)	3 1/2 (89)
1/2" ANSI 300 lb weld neck raised face flange	314	7 1/8 (181)	3 3/4 (95)
1/2" ANSI 600 lb weld neck raised face flange	315	7 5/8 (194)	3 3/4 (95)
1/2" NPT female union fitting	319	4 11/16 (119)	----
1/2" sanitary fitting	321	4 11/16 (119)	1 (25)
15 mm DIN PN40 weld neck, DIN 2635, type C facing	300	6 5/16 (160)	3 3/4 (95)
15 mm DIN PN40 weld neck, DIN 2635, type N grooved facing	301	6 5/16 (160)	3 3/4 (95)
15 mm DIN PN100 weld neck, DIN 2637, type E facing	302	6 15/16 (176)	4 1/8 (105)
15 mm DIN PN100 weld neck, DIN 2637, type N grooved facing	303	6 15/16 (176)	4 1/8 (105)
15 mm JIS 10K weld neck	304	6 1/8 (156)	3 3/4 (95)
15 mm JIS 20K weld neck	305	6 1/8 (156)	3 3/4 (95)
Fittings for nickel alloy sensors⁽¹⁾			
1/2" ANSI 150 lb lap joint flange	520	6 3/4 (172)	3 1/2 (89)
1/2" ANSI 300 lb lap joint flange	521	7 1/8 (181)	3 3/4 (95)
15 mm DIN PN40 lap joint flange, DIN 2626	523	7 5/16 (186)	3 3/4 (95)
15 mm JIS 10K lap joint flange	522	7 1/8 (181)	3 3/4 (95)

⁽¹⁾ Fittings listed here are standard options. Other types of fittings are available. Contact your local Micro Motion representative.

CMF050 dimensions and process fittings

Dimensions in inches
(mm)

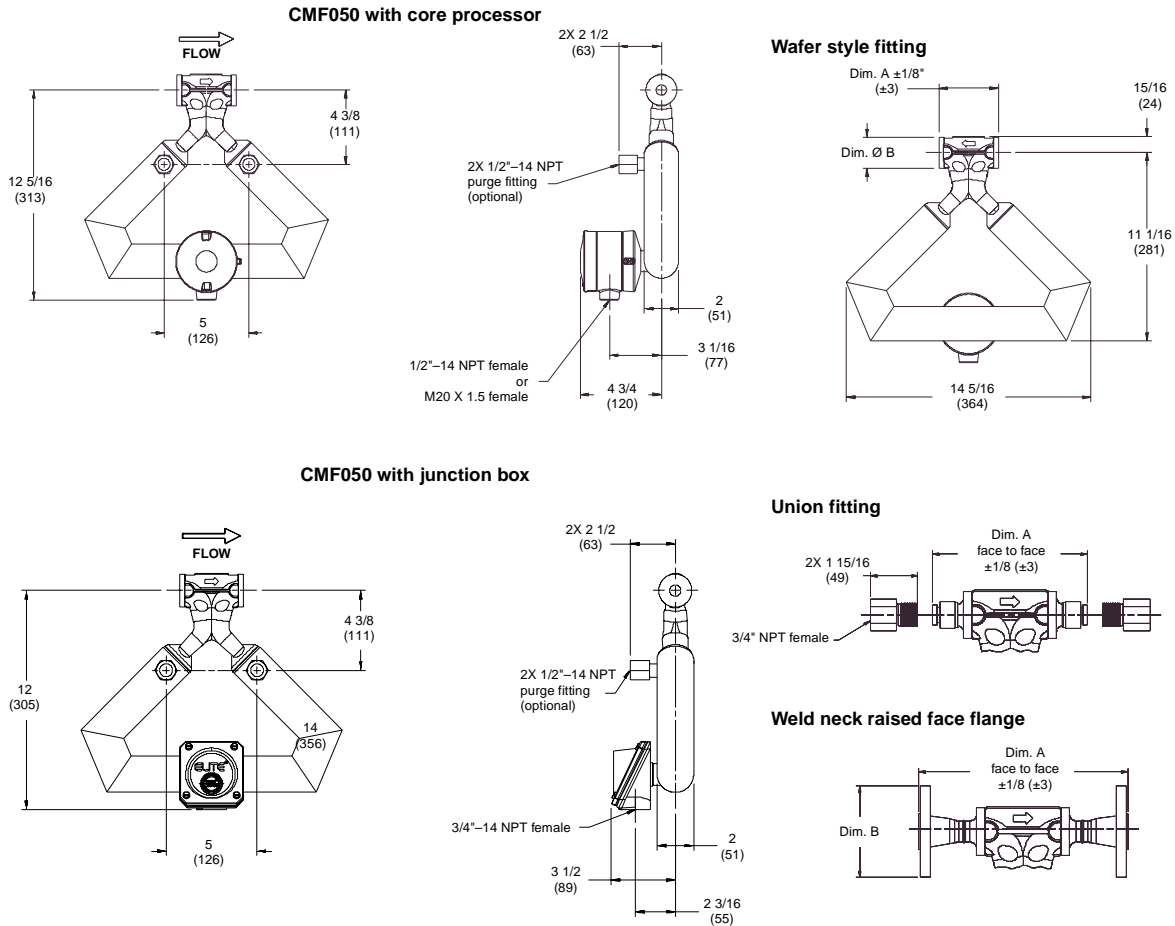

Fittings for stainless steel sensors ⁽¹⁾	Fitting code	Dim. A Face-to-face	Dim. B Outside diam.
Wafer style, 1/2" ANSI (150 lb, 300 lb, 600 lb bolt kit)	009	3 1/2 (89)	1 13/16 (46)
Wafer style, 15 mm DIN 2635, type C facing (PN40 bolt kit)	016	3 1/2 (89)	1 13/16 (46)
Wafer style, 15 mm DIN 2635, type N grooved facing (PN40 bolt kit)	017	3 1/2 (89)	1 13/16 (46)
Wafer style, 15 mm DIN 2637, type E facing (PN100 bolt kit)	018	3 1/2 (89)	1 13/16 (46)
Wafer style, 15 mm DIN 2637, type N grooved facing (PN100 bolt kit)	019	3 1/2 (89)	1 13/16 (46)
Wafer style, 15 mm (10K, 20K bolt kit)	029	3 1/2 (89)	1 13/16 (46)
1/2" ANSI 150 lb weld neck raised face flange	313	7 15/16 (202)	3 1/2 (89)
1/2" ANSI 300 lb weld neck raised face flange	314	8 5/16 (211)	3 3/4 (95)
1/2" ANSI 600 lb weld neck raised face flange	315	8 13/16 (224)	3 3/4 (95)
3/4" NPT female union fitting	320	6 1/2 (165)	----
3/4" sanitary fitting	322	6 1/2 (165)	1 (25)
15 mm DIN PN40 weld neck, DIN 2635, type C facing	300	7 1/2 (191)	3 3/4 (95)
15 mm DIN PN40 weld neck, DIN 2635, type N grooved facing	301	7 1/2 (191)	3 3/4 (95)
15 mm DIN PN100 weld neck, DIN 2637, type E facing	302	8 1/16 (205)	4 1/8 (105)
15 mm DIN PN100 weld neck, DIN 2637, type N grooved facing	303	8 1/16 (205)	4 1/8 (105)
15 mm JIS 10K weld neck	304	7 1/4 (184)	3 3/4 (95)
15 mm JIS 20K weld neck	305	7 1/4 (184)	3 3/4 (95)
Fittings for nickel alloy sensors⁽¹⁾			
1/2" ANSI 150 lb lap joint flange	520	7 15/16 (202)	3 1/2 (89)
1/2" ANSI 300 lb lap joint flange	521	8 5/16 (211)	3 3/4 (95)
15 mm DIN PN40 lap joint flange, DIN 2626	523	8 1/2 (216)	3 3/4 (95)
15 mm JIS 10K lap joint flange	522	8 1/4 (210)	3 3/4 (95)

⁽¹⁾ Fittings listed here are standard options. Other types of fittings are available. Contact your local Micro Motion representative.

CMF100 dimensions and process fittings

Dimensions in inches
(mm)

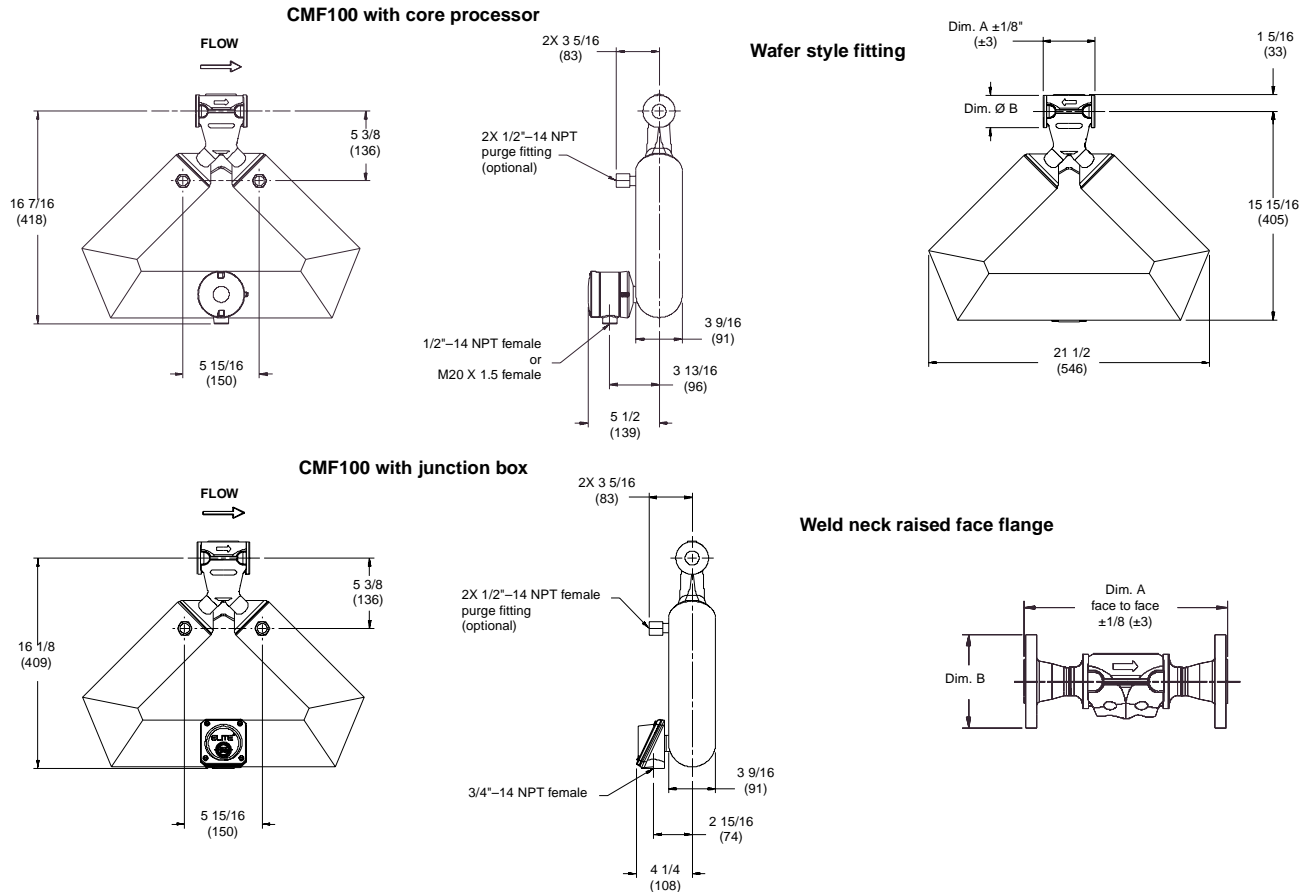

Fittings for stainless steel sensors⁽¹⁾

	Fitting code	Dim. A Face-to-face	Dim. B Outside diam.
Wafer style, 1" ANSI (150 lb bolt kit)	010	4 (102)	2 1/2 (64)
Wafer style, 1" ANSI (300 lb, 600 lb bolt kit)	011	4 (102)	2 1/2 (64)
Wafer style, 25 mm DIN 2635, type C facing (PN40 bolt kit)	020	4 (102)	2 1/2 (64)
Wafer style, 25 mm DIN 2635, type N grooved facing (PN40 bolt kit)	021	4 (102)	2 1/2 (64)
Wafer style, 25 mm DIN 2637, type E facing (PN100 bolt kit)	022	4 (102)	2 1/2 (64)
Wafer style, 25 mm DIN 2637, type N grooved facing (PN100 bolt kit)	023	4 (102)	2 1/2 (64)
Wafer style, 25 mm (10K, 20K, 30K bolt kit)	030	4 (102)	2 1/2 (64)
1" ANSI 150 lb weld neck raised face flange	328	9 1/4 (235)	4 1/4 (108)
1" ANSI 300 lb weld neck raised face flange	329	9 3/4 (248)	4 7/8 (124)
1" ANSI 600 lb weld neck raised face flange	330	10 1/4 (260)	4 7/8 (124)
1 1/2" ANSI 600 lb weld neck raised face flange	331	10 7/8 (276)	6 1/8 (156)
1" sanitary fitting	339	8 3/8 (213)	2 (50)
25 mm DIN PN40 weld neck, DIN 2635, type C facing	306	8 5/16 (211)	4 1/2 (115)
25 mm DIN PN40 weld neck, DIN 2635, type N grooved facing	307	8 5/16 (211)	4 1/2 (115)
25 mm DIN PN100 weld neck, DIN 2637, type E facing	308	9 11/16 (246)	5 1/2 (140)
25 mm DIN PN100 weld neck, DIN 2637, type N grooved facing	309	9 11/16 (246)	5 1/2 (140)
25 mm JIS 10K weld neck	317	8 5/16 (211)	4 15/16 (125)
25 mm JIS 20K weld neck	318	8 5/16 (211)	4 15/16 (125)

Fittings for nickel alloy sensors⁽¹⁾

1" ANSI 150 lb lap joint flange	530	9 1/4 (235)	4 1/4 (108)
1" ANSI 300 lb lap joint flange	531	9 3/4 (248)	4 7/8 (124)
25 mm DIN PN40 lap joint flange, DIN 2626	533	9 9/16 (243)	4 1/2 (115)
25 mm JIS 10K lap joint flange	532	9 5/16 (237)	4 15/16 (125)

⁽¹⁾ Fittings listed here are standard options. Other types of fittings are available. Contact your local Micro Motion representative.

CMF200 dimensions and process fittings

Dimensions in inches (mm)

CMF200 with core processor

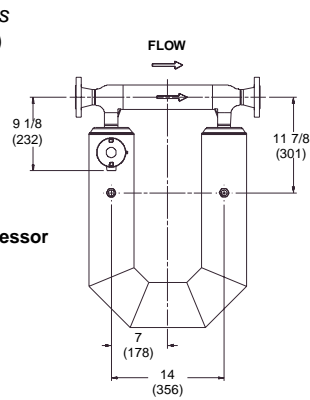

CMF200 with junction box

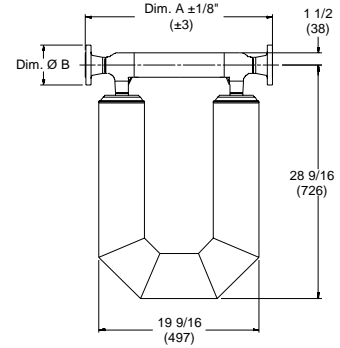
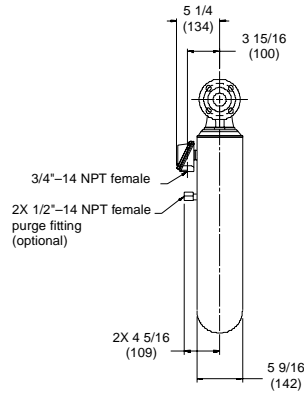
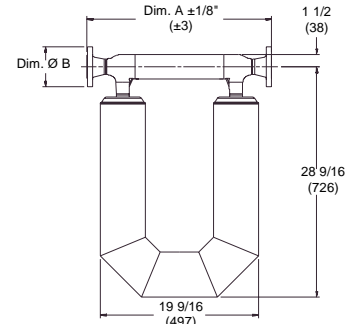
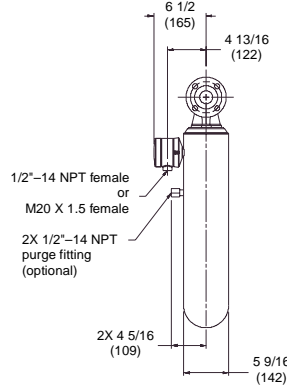
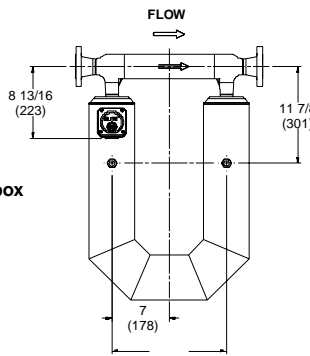

Fittings for stainless steel sensors⁽¹⁾

	Fitting code	Dim. A Face-to-face	Dim. B Outside diam.
1 1/2" ANSI 150 lb weld neck raised face flange	341	22 7/8 (581)	5 (127)
1 1/2" ANSI 300 lb weld neck raised face flange	342	23 3/8 (594)	6 1/8 (156)
1 1/2" ANSI 600 lb weld neck raised face flange	343	23 7/8 (606)	6 1/8 (156)
2" ANSI 150 lb weld neck raised face flange	418	22 7/8 (581)	6 (152)
2" ANSI 300 lb weld neck raised face flange	419	23 3/8 (594)	6 1/2 (165)
2" ANSI 600 lb weld neck raised face flange	420	23 5/8 (600)	6 1/2 (165)
1 1/2" sanitary fitting	351	21 3/8 (543)	2 (51)
2" sanitary fitting	352	21 3/8 (543)	2 1/2 (64)
40 mm DIN PN40 weld neck, DIN 2635, type C facing	381	21 11/16 (551)	5 15/16 (150)
40 mm DIN PN40 weld neck, DIN 2635, type N grooved facing	383	21 11/16 (551)	5 15/16 (150)
40 mm DIN PN100 weld neck, DIN 2637, type E facing	377	23 1/8 (587)	6 11/16 (170)
40 mm DIN PN100 weld neck, DIN 2637, type N grooved facing	379	23 1/8 (587)	6 11/16 (170)
50 mm DIN PN40 weld neck, DIN 2635, type C facing	382	21 15/16 (557)	6 1/2 (165)
50 mm DIN PN40 weld neck, DIN 2635, type N grooved facing	384	21 15/16 (557)	6 1/2 (165)
50 mm DIN PN100 weld neck, DIN 2637, type E facing	378	23 9/16 (598)	7 11/16 (195)
50 mm DIN PN100 weld neck, DIN 2637, type N grooved facing	380	23 9/16 (598)	7 11/16 (195)
40 mm JIS 10K weld neck	385	21 9/16 (548)	5 1/2 (140)
40 mm JIS 20K weld neck	387	21 9/16 (548)	5 1/2 (140)
50 mm JIS 10K weld neck	386	21 13/16 (554)	6 1/8 (156)
50 mm JIS 20K weld neck	388	21 13/16 (554)	6 1/8 (156)

Fittings for nickel alloy sensors⁽¹⁾

1 1/2" ANSI 150 lb lap joint flange	540	22 7/8 (581)	5 (127)
1 1/2" ANSI 300 lb lap joint flange	541	23 3/8 (594)	6 1/8 (156)
2" ANSI 150 lb lap joint flange	544	22 7/8 (581)	6 (152)
2" ANSI 300 lb lap joint flange	545	23 3/8 (594)	6 1/2 (165)
40 mm DIN PN40 lap joint flange, DIN 2626	543	21 11/16 (551)	5 15/16 (150)
50 mm DIN PN40 lap joint flange, DIN 2626	547	21 15/16 (557)	6 1/2 (165)
40 mm JIS 10K lap joint flange	542	21 9/16 (548)	5 1/2 (140)
50 mm JIS 10K lap joint flange	546	21 13/16 (554)	6 1/8 (155)

⁽¹⁾ Fittings listed here are standard options. Other types of fittings are available. Contact your local Micro Motion representative.

CMF300 dimensions and process fittings

Dimensions in inches
(mm)

CMF300 with core processor

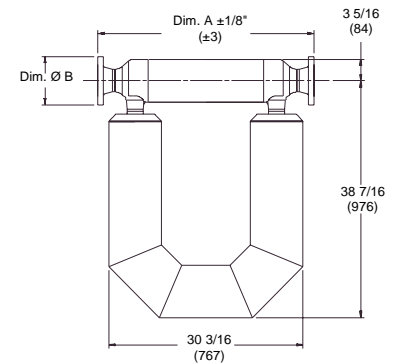
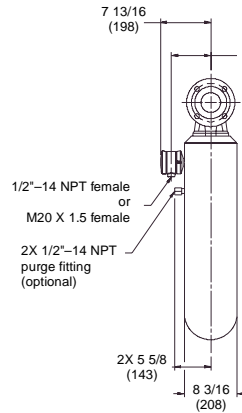
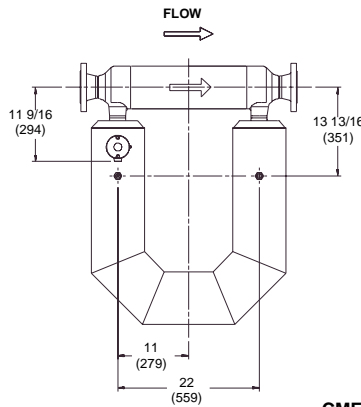

CMF300 with junction box

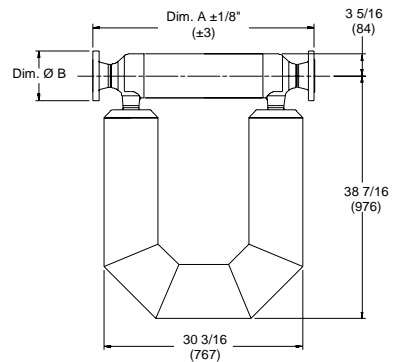
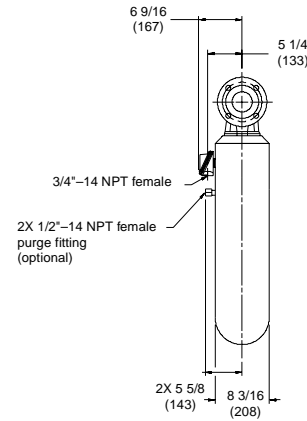
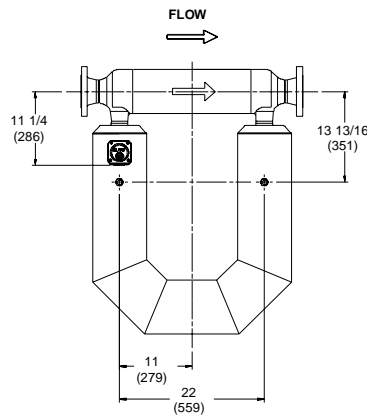

Fittings for stainless steel sensors⁽¹⁾

	Fitting code	Dim. A Face-to-face	Dim. B Outside diam.
3" ANSI 150 lb weld neck raised face flange	355	33 11/16 (856)	7 1/2 (191)
3" ANSI 300 lb weld neck raised face flange	356	34 7/16 (875)	8 1/4 (210)
3" ANSI 600 lb weld neck raised face flange	357	35 3/16 (894)	8 1/4 (210)
4" ANSI 150 lb weld neck raised face flange	425	34 1/16 (865)	9 (229)
4" ANSI 300 lb weld neck raised face flange	426	35 (889)	10 (254)
4" ANSI 600 lb weld neck raised face flange	427	36 11/16 (932)	10 3/4 (273)
3" sanitary fitting	361	32 (813)	3 9/16 (90)
80 mm DIN PN40 weld neck, DIN 2635, type C facing	391	32 7/8 (835)	7 7/8 (200)
80 mm DIN PN40 weld neck, DIN 2635, type N grooved facing	393	32 7/8 (835)	7 7/8 (200)
80 mm DIN PN100 weld neck, DIN 2637, type E facing	395	34 9/16 (878)	9 1/16 (230)
80 mm DIN PN100 weld neck, DIN 2637, type N grooved facing	397	34 9/16 (878)	9 1/16 (230)
100 mm DIN PN40 weld neck, DIN 2635, type C facing	392	33 7/16 (849)	9 1/4 (235)
100 mm DIN PN40 weld neck, DIN 2635, type N grooved facing	394	33 7/16 (849)	9 1/4 (235)
100 mm DIN PN100 weld neck, DIN 2637, type E facing	396	35 9/16 (903)	10 7/16 (265)
100 mm DIN PN100 weld neck, DIN 2637, type N grooved facing	398	35 9/16 (903)	10 7/16 (265)
80 mm JIS 10K weld neck	400	33 3/8 (848)	7 5/16 (186)
80 mm JIS 20K weld neck	402	33 3/8 (848)	7 7/8 (200)
100 mm JIS 10K weld neck	401	33 9/16 (853)	8 1/4 (210)
100 mm JIS 20K weld neck	403	33 9/16 (853)	8 7/8 (225)

Fittings for nickel alloy sensors⁽¹⁾

3" ANSI 150 lb lap joint flange	550	33 11/16 (856)	7 1/2 (191)
3" ANSI 300 lb lap joint flange	551	34 7/16 (875)	8 1/4 (210)
80 mm DIN PN40 lap joint flange, DIN 2626	553	32 7/8 (835)	7 7/8 (200)
80 mm JIS 10K lap joint flange	552	33 3/8 (848)	7 5/16 (185)

⁽¹⁾ Fittings listed here are standard options. Other types of fittings are available. Contact your local Micro Motion representative.

High-temperature CMF300A dimensions and process fittings

Dimensions in inches
(mm)

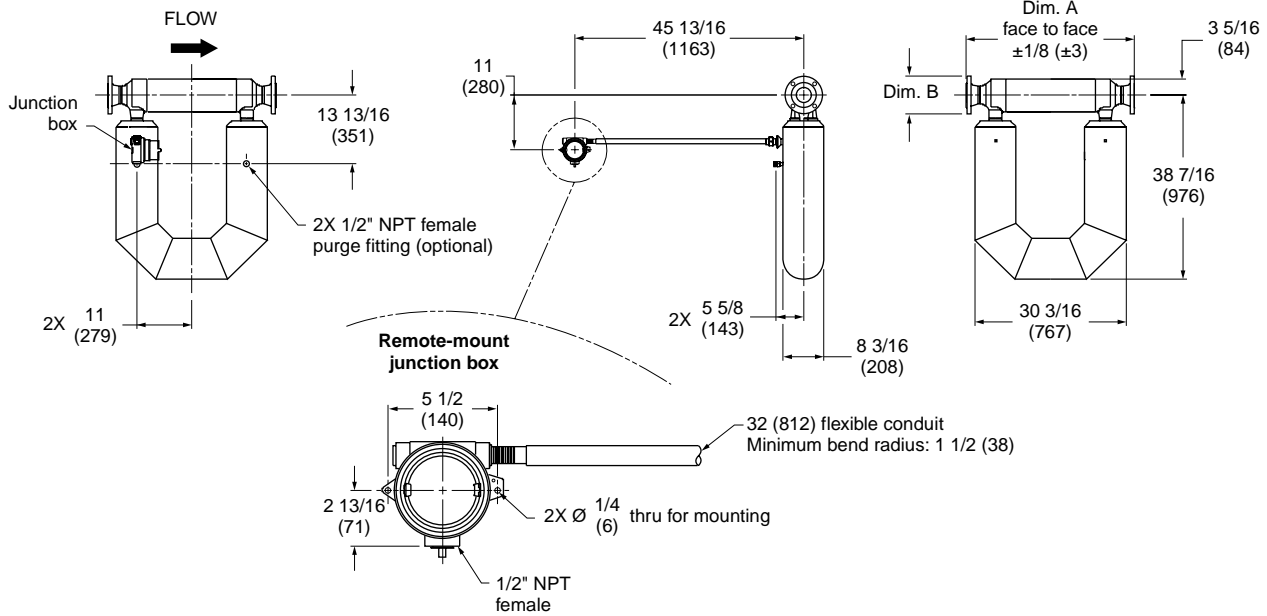

Fittings ⁽¹⁾	Fitting code	Dim. A Face-to-face	Dim. B Outside diam.
3" ANSI 150 lb weld neck raised face flange	355	33 11/16 (856)	7 1/2 (190)
3" ANSI 300 lb weld neck raised face flange	356	34 7/16 (875)	8 1/4 (210)
3" ANSI 600 lb weld neck raised face flange	357	35 3/16 (894)	8 1/4 (210)
3" ANSI 900 lb weld neck raised face flange	358	36 11/16 (932)	9 1/2 (241)
4" ANSI 150 lb weld neck raised face flange	425	34 1/16 (865)	9 (229)
4" ANSI 300 lb weld neck raised face flange	426	35 (889)	10 (254)
4" ANSI 600 lb weld neck raised face flange	427	36 11/16 (932)	10 3/4 (273)
4" ANSI 900 lb weld neck raised face flange	428	37 3/16 (945)	11 1/2 (292)
80 mm DIN PN40 weld neck, DIN 2635, type C facing	391	32 7/8 (835)	7 7/8 (200)
80 mm DIN PN40 weld neck, DIN 2635, type N grooved facing	393	32 7/8 (835)	7 7/8 (200)
80 mm DIN PN100 weld neck, DIN 2637, type E facing	395	34 9/16 (878)	9 1/16 (230)
80 mm DIN PN100 weld neck, DIN 2637, type N grooved facing	397	34 9/16 (878)	9 1/16 (230)
100 mm DIN PN40 weld neck, DIN 2635, type C facing	392	33 7/16 (849)	9 1/4 (235)
100 mm DIN PN40 weld neck, DIN 2635, type N grooved facing	394	33 7/16 (849)	9 1/4 (235)
100 mm DIN PN100 weld neck, DIN 2637, type E facing	396	35 9/16 (903)	10 7/16 (265)
100 mm DIN PN100 weld neck, DIN 2637, type N grooved facing	398	35 9/16 (903)	10 7/16 (265)
80 mm JIS 10K weld neck	400	33 3/8 (848)	7 5/16 (185)
80 mm JIS 20K weld neck	402	33 3/8 (848)	7 7/8 (200)
100 mm JIS 10K weld neck	401	33 9/16 (852)	8 1/4 (210)
100 mm JIS 20K weld neck	403	33 9/16 (852)	8 7/8 (225)

⁽¹⁾ Fittings listed here are standard options. Other types of fittings are available. Contact your local Micro Motion representative.

CMF400 dimensions

Dimensions in inches (mm)

CMF400 with integrally mounted booster amplifier and core processor

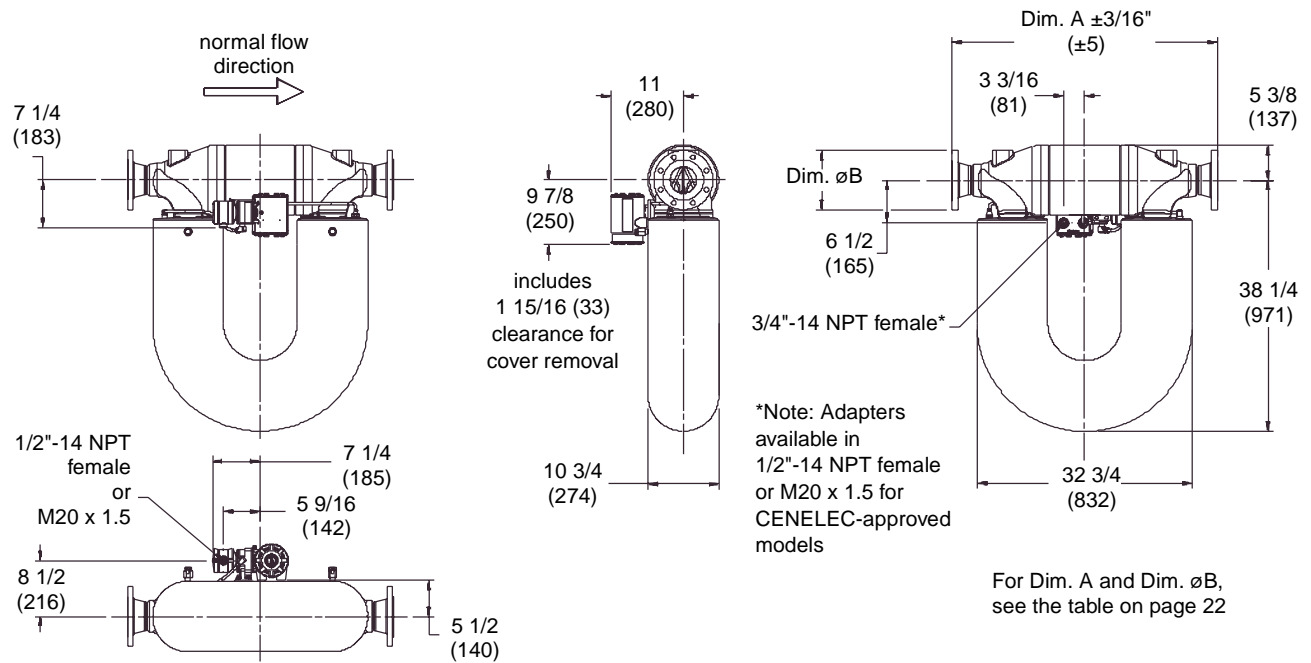

CMF400 with integrally mounted booster amplifier and junction box

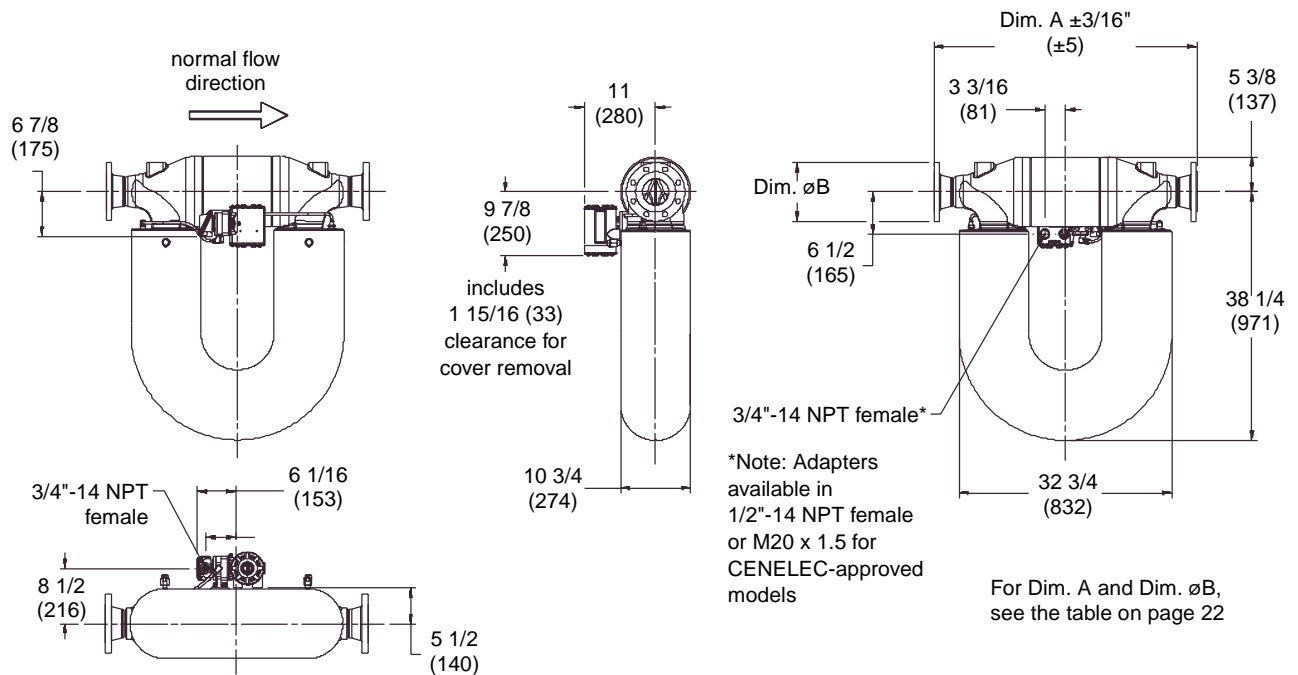

CMF400 dimensions and process fittings

Dimensions in inches
(mm)

CMF400 for remotely mounted booster amplifier

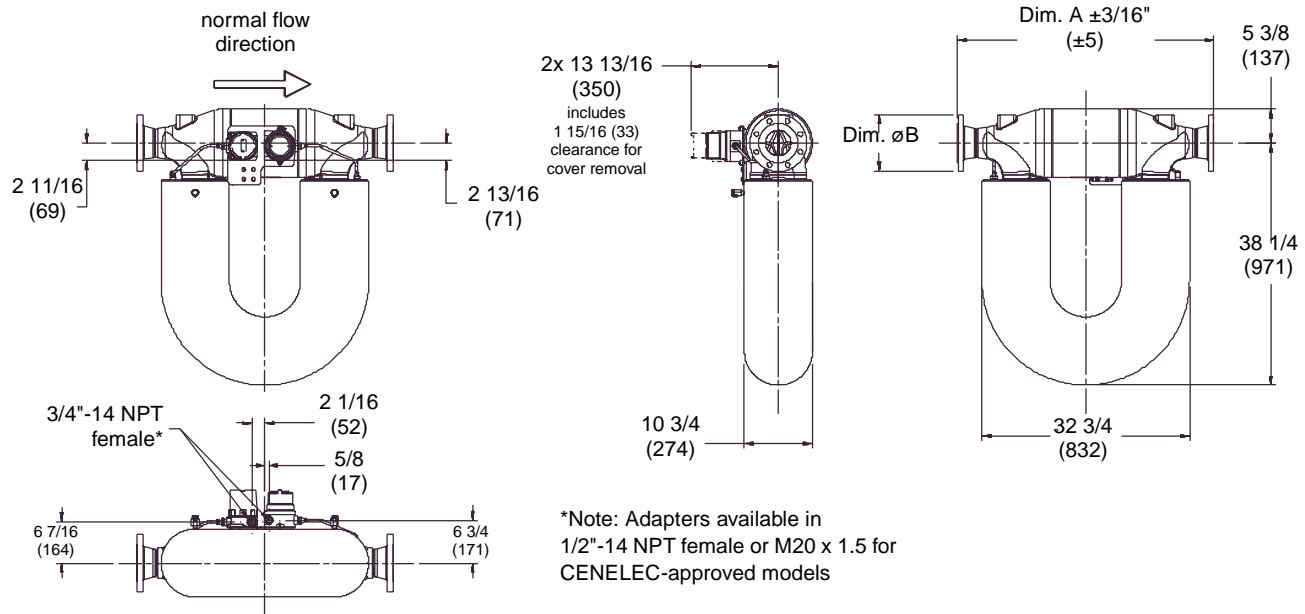

Fittings ⁽¹⁾	Fitting code	Dim. A Face-to-face	Dim. B Outside diam.
4" ANSI 150 lb weld neck raised face flange	435	40 3/16 (1021)	9 (229)
4" ANSI 300 lb weld neck raised face flange	436	41 (1041)	10 (254)
4" ANSI 600 lb weld neck raised face flange	437	42 11/16 (1084)	10 3/4 (273)
6" ANSI 150 lb weld neck raised face flange	451	40 5/16 (1024)	11 (279)
6" ANSI 300 lb weld neck raised face flange	452	41 5/16 (1049)	12 1/2 (318)
6" ANSI 600 lb weld neck raised face flange	453	43 1/2 (1105)	14 (356)
100 mm DIN PN40 weld neck, DIN 2635, type C facing	460	39 5/16 (999)	9 1/4 (235)
100 mm DIN PN40 weld neck, DIN 2635, type N facing	462	39 5/16 (999)	9 1/4 (235)
100 mm DIN PN100 weld neck, DIN 2637, type E facing	464	41 5/16 (1049)	10 7/16 (265)
100 mm DIN PN100 weld neck, DIN 2637, type N facing	466	41 5/16 (1049)	10 7/16 (265)
150 mm DIN PN40 weld neck, DIN 2635, type C facing	461	39 5/8 (1006)	11 13/16 (300)
150 mm DIN PN40 weld neck, DIN 2635, type N facing	463	39 5/8 (1006)	11 13/16 (300)
150 mm DIN PN100 weld neck, DIN 2637, type E facing	465	41 15/16 (1065)	14 (355)
150 mm DIN PN100 weld neck, DIN 2637, type N facing	467	41 15/16 (1065)	14 (355)
100 mm JIS 10K weld neck	470	39 5/16 (999)	8 1/4 (210)
100 mm JIS 20K weld neck	472	39 13/16 (1011)	8 7/8 (225)
150 mm JIS 10K weld neck	471	39 5/8 (1006)	11 (280)
150 mm JIS 20K weld neck	473	40 1/8 (1018)	12 (305)

⁽¹⁾ Fittings listed here are standard options. Other types of fittings are available. Contact your local Micro Motion representative.

CMF400 remote booster amplifier

Dimensions in inches
(mm)

Remote mount booster amplifier with core processor

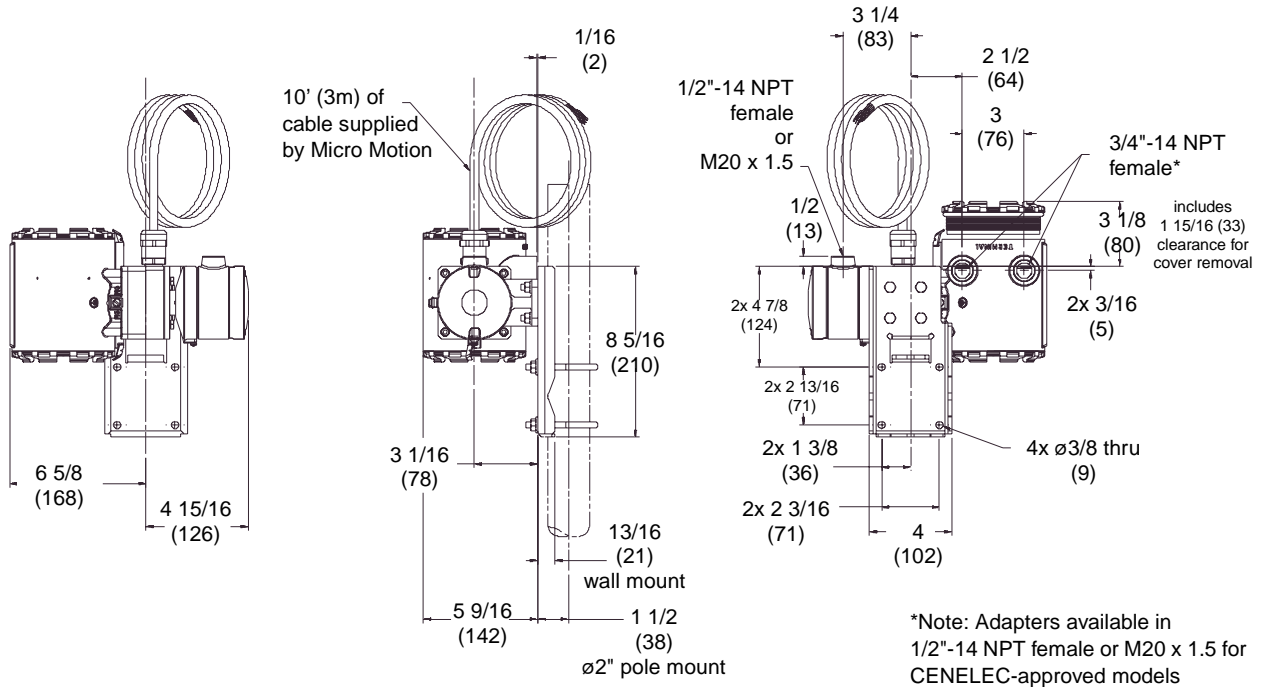

Remote mount booster amplifier with junction box

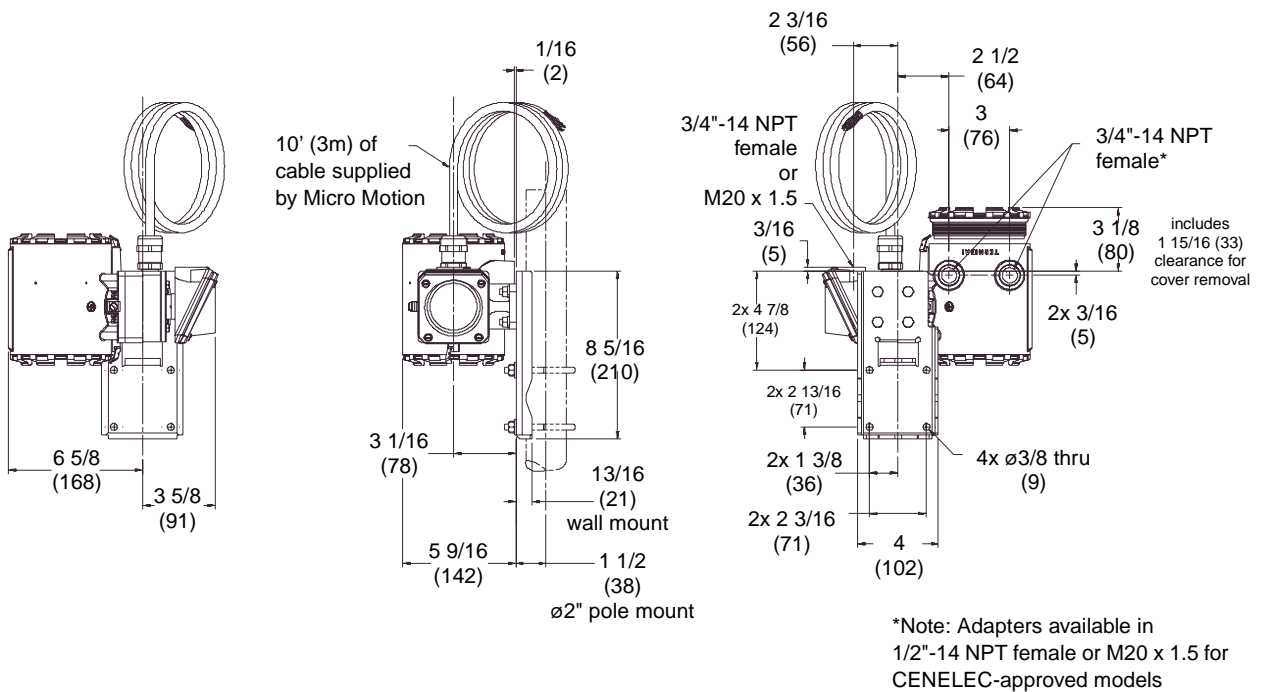

Ordering information

ELITE sensor model number matrix

Model	Sensor Model
CMF010	ELITE® 1/8 inch sensor
CMF025	ELITE® 1/4 inch sensor
CMF050	ELITE® 1/2 inch sensor
CMF100	ELITE® 1 inch sensor
CMF200	ELITE® 2 inch sensor
CMF300	ELITE® 3 inch sensor
CMF400	ELITE® 4 inch sensor
Code	Pressure, temperature and wetted material
M	Standard pressure, standard temperature, 316L stainless steel
H	Standard pressure, standard temperature, Nickel Alloy - Not available with CMF010 or CMF400
N	Standard pressure, standard temperature, Inconel 686 - CMF010 only
A	Standard pressure, high temperature, 316L stainless steel - CMF300A
P	High pressure, standard temperature, Inconel 686 nickel alloy and 316L stainless steel - CMF010 only
Code	Process Connections
###	See fittings tables on pages 14-22
Code	Case Options
N	Standard pressure containment
P	Purge fittings (two 1/2-inch NPT female, not available with CMF400)
D	Rupture disks (two 400-psi disks) - CMF010 with pressure/material code P only
Code	Electronics Interface
A	Local core processor for remote mount Series 1000/2000 - not available with CMF300A or CMF400
D	MVDSolo, local core processor for direct host connections (for OEM's) ⁽¹⁾
R	9 wire junction box - not available with CMF400 <u>For CMF400 only</u>
K	Integral Booster Amp with local core processor to remote mount Series 1000/2000 transmitters
L	Integral Booster Amp with MVDSolo, local core processor for direct host connection (for OEM's) ⁽¹⁾
M	Integral Booster Amp w/ 9 wire junction box
N	Remote Booster Amp with local core processor to remote mount Series 1000/2000 transmitters
O	Remote Booster Amp with MVDSolo, local core processor for direct host connection (for OEM's) ⁽¹⁾
P	Remote Booster Amp w/ 9 wire junction box
Code	Conduit Connections
	Electronics Interface Code 'A', 'K', 'L', 'N' and 'O' (Local core processor)
B	1/2 inch NPT-no gland
C	1/2 inch NPT with brass nickel cable gland (cable dia. .335 in. to .394 in.)
D	1/2 inch NPT with stainless steel cable gland (cable dia. .335 in. to .394 in.)
E	M20-no gland
F	M20 brass nickel cable gland (cable dia. 8.5mm to 10.0mm)
G	M20 stainless steel cable gland (cable dia. 8.5mm to 10.0mm)
	Electronics Interface Code 'R', 'M' and 'P' (9 wire junction box)
A	3/4" NPT - no gland
H	3/4" NPT with brass nickel gland
J	3/4" NPT with stainless steel gland

Ordering information

ELITE sensor model number matrix

continued on next page

Code	Approvals
M	For All Sensor Types
U	Micro Motion Standard (no approval)
C	UL
A	CSA (Canada only)
Z	CSA (US and Canada)
F	CENELEC - Increased Safety
S	CENELEC - flameproof (CMF400 only)
S	SAA - 9 wire junction box models only, not available with CMF400 or temperature code A
Code	Language
A	Danish Quick Reference and English Manual
D	Dutch Quick Reference and English Manual
E	English Quick Reference and English Manual
F	French Quick Reference and French Manual
G	German Quick Reference and German Manual
H	Finnish Quick Reference and English Manual
I	Italian Quick Reference and English Manual
J	Japanese Quick Reference and English Manual
M	Chinese Quick Reference and English Manual
N	Norwegian Quick Reference and English Manual
O	Polish Quick Reference and English Manual
P	Portugese Quick Reference and English Manual
R	Russian Quick Reference and English Manual
S	Spanish Quick Reference and English Manual
W	Swedish Quick Reference and English Manual
Code	Connection to Booster Amp - CMF400 only
A	3/4-inch NPT conduit opening
B	M20 Brass Nickel Adapter ⁽²⁾
C	M20 Stainless Steel Adapter ⁽²⁾
D	1/2-inch NPT Brass Nickel Adapter ⁽²⁾
E	1/2-inch NPT Stainless Steel Adapter ⁽²⁾
Code	Future Options
ZZ	Reserved for future use
Code	Future Options
Z	Reserved for future use - not available on CMF400
Typical Model Number: CMF010M 313 N A B U E ZZ Z	

⁽¹⁾ Safe area, no approvals

⁽²⁾ CENELEC approval only

Due to Micro Motion's commitment to continuous improvement of our products, all specifications are subject to change without notice. Micro Motion, ELITE, and MVD are registered trademarks of Micro Motion, Inc., Boulder, Colorado. Plantweb is a registered trademark, and Fisher-Rosemount is a trademark of Fisher-Rosemount, Clayton, Missouri. HART is a registered trademark of the HART Communication Foundation, Austin, Texas. Modbus is a registered trademark of Modicon, Inc., North Andover, Massachusetts. FOUNDATION is a trademark of the Fieldbus Foundation, Austin, Texas. Hastelloy is a registered trademark of Haynes International, Inc., Kokomo, Indiana. Inconel is a registered trademark of Inco Alloys International, Inc., Huntington, West Virginia.

For the latest Micro Motion product specifications, view the PRODUCTS section of our Web site at www.micromotion.com

Micro Motion Europe

Groeneveldselaan 8
3903 AZ Veenendaal
The Netherlands
Tel +31 (0) 318 549 549
Fax +31 (0) 318 549 559

Micro Motion Asia

1 Pandan Crescent
Singapore 128461
Republic of Singapore
Tel (65) 777-8211
Fax (65) 770-8003

**Micro Motion Inc. USA
Worldwide Headquarters**

7070 Winchester Circle
Boulder, Colorado 80301
Tel 303-530-8400
800-522-6277
Fax 303-530-8459

Micro Motion Japan

Shinagawa NF Bldg. 5F
1-2-5, Higashi Shinagawa
Shinagawa-ku
Tokyo 140-0002 Japan
Tel (81) 3 5769-6803
Fax (81) 3 5769-6843

Micro Motion
FISHER-ROSEMOUNT™