

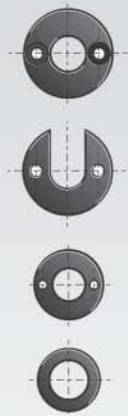

- General data
- Analog interface
- Digital pulse interface
- SSD interface
- CANopen interface
- PROFIBUS-DP interface
- Magnets and floats
- Installation notes
- Special series

- B.2** General data
- B.4** Analog interface
- B.6** Digital pulse interface
- B.8** SSD interface
- B.10** CANopen interface
- B.12** PROFIBUS-DP interface
- B.14** Magnets and floats
- B.16** Installation notes
- B.18** Special series



**Pressure rated to 600 bar,
high repeatability,
non-contact, rugged**

The BTL Micropulse transducer is the rugged position feedback system for use under extreme ambient conditions measuring between 25 and 4000 mm.

The actual waveguide is protected inside a high-pressure resistant stainless steel tube. The system is ideal for use in hydraulic cylinders for position feedback or as a level monitor with aggressive media in the food and chemical industries.

Series	BTL5 Rod-style
Shock load	100 g/6 ms per IEC 60068-2-27
Vibration	12 g, 10...2000 Hz per IEC 60068-2-6
Polarity reversal protected	yes
Overvoltage protection	Transzorb protection diodes
Dielectric strength	500 V (GND to housing)
Enclosure rating per IEC 60529	IP 67 (when BKS-S... IP 67 connector is in place)
Housing material	Anodized aluminum/1.4571 stainless tube, 1.3952 stainless investment cast flange
Mounting	thread M18x1,5, 3/4"-16UNF on request
Pressure rating	600 bar installed in hydraulic cylinder
Connection type	connector or integral cable
EMC testings:	
RF emission	EN 55011 Group 1, Class A
Static electricity (ESD)	IEC 61000-4-2 Severity Level 3
Electromagnetic fields (RFI)	IEC 61000-4-3 Severity Level 3
Fast transients (BURST)	IEC 61000-4-4 Severity Level 4
Line-carried noise, induced by high-frequency fields	IEC 61000-4-6 Severity Level 3
Standard nominal strokes [mm]	0025, 0050, 0075, 0100, 0125, 0150, 0175, 0200, 0225, 0250, 0275, 0300, 0325, 0350, 0375, 0400, 0425, 0450, 0475, 0500, 0550, 0600, 0650, 0700, 0750, 0800, 0850, 0900, 0950, 1000, 1100, 1200, 1300, 1400, 1500, 1600, 1700, 1800, 1900, 2000, 2250, 2500, 2750, 3000, 3250, 3500, 3750, 3850, 4000 or in 5-mm increments on request

- Included
- Transducer (select your interface starting page **B.4**)
 - Jam nuts M18x1.5
 - User's manual

Please order separately:
Magnets page **B.14**
Floats page **B.15**
Connectors starting page **BKS.3**

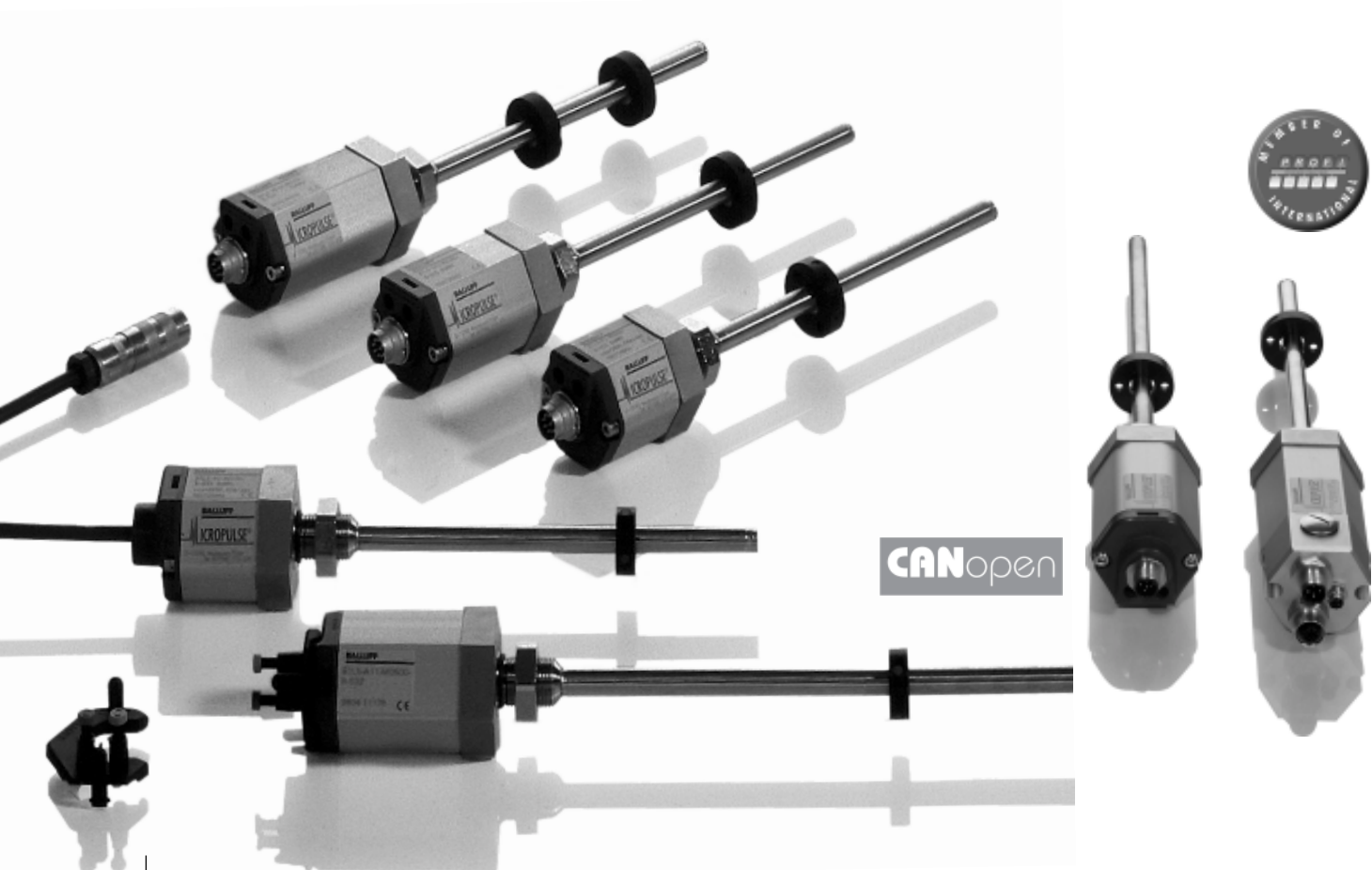

Series

BTL5 Rod-style

Transducer, Magnet, S 32 connector with BKS-S 32M-_/BKS-S 33M connector for transducers with analog interface, digital pulse interface and SSD interface, see Page B.4...B.9

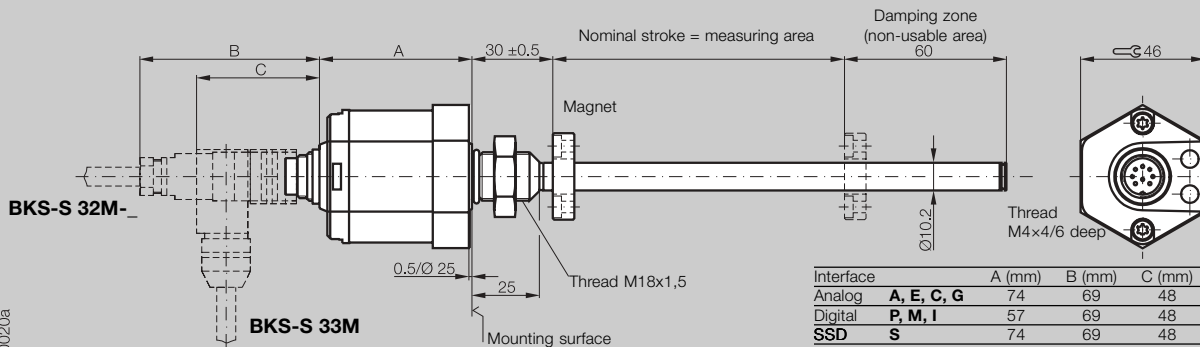

PL0020a

Transducer with integrated cable

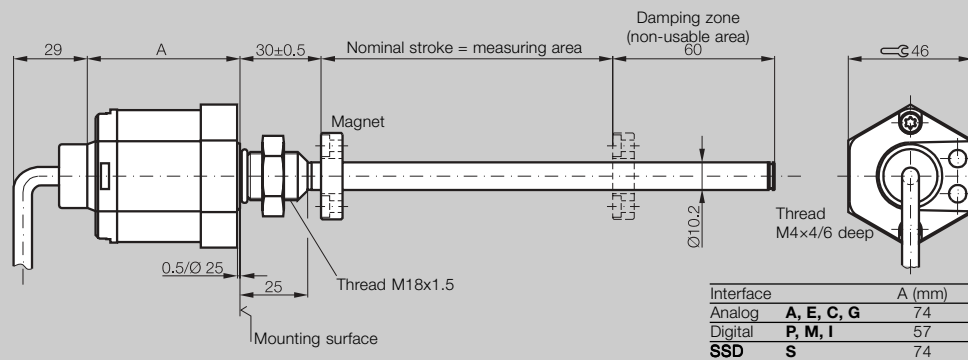

PL0021a

CANopen, S 92 plug with BKS-S 92-00 connector for transducers with CANopen interface see Page B.10

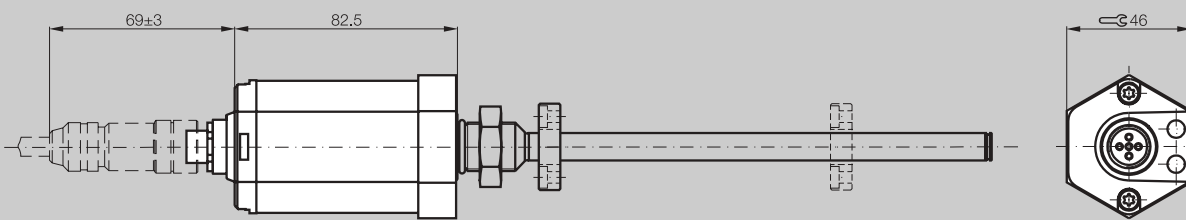

PL0045

PROFIBUS-DP, S103 plug with BKS-S 103-00, BKS-S 105-00 and BKS-S 48-15-CP-__ connector for transducers with PROFIBUS-DP interface see Page B.12

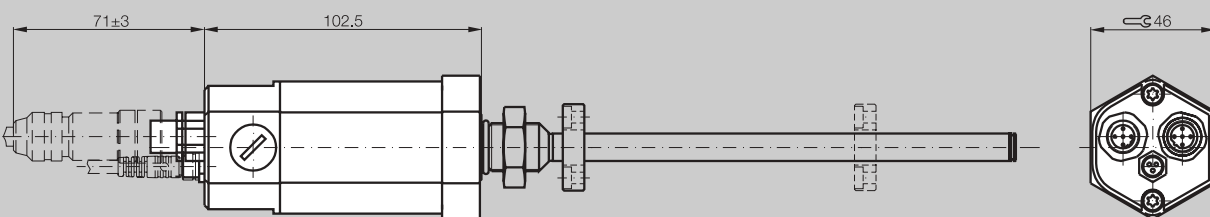

PL0046

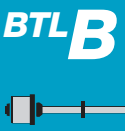

General data

- Analog interface
- Digital pulse interface
- SSD interface
- CANopen interface
- PROFIBUS-DP interface
- Magnets and floats
- Installation notes
- Special series



Page **BKS.3**

Series
Output signal
Transducer interface
Input interface

100 % Null- and endpoint calibration

Null and endpoint of the analog signal can be button-set to the desired position. Depending on the application, teach-in or adjust mode is used, selectable by pressing a button combination.

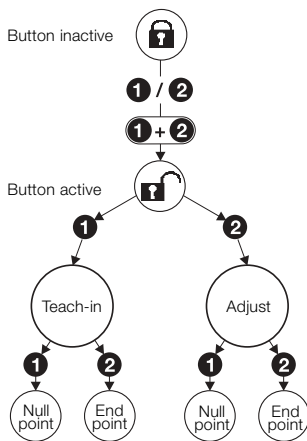

Select calibration method

Teach-in

Used for changing the factory set null and end point with a new null and end point. First the magnet must be brought to the new null point and then to the new end position, and the respective values stored by pressing the button.

Adjust

Here you can adjust to a new start and end value. This may be required when you cannot physically move the magnet to the standard null and/or end point. Move the magnet to the new start and end position, and adjust the displayed value by pressing the button until the desired output values are reached.

**Calibration device 115379
BTL5-A-EH01**

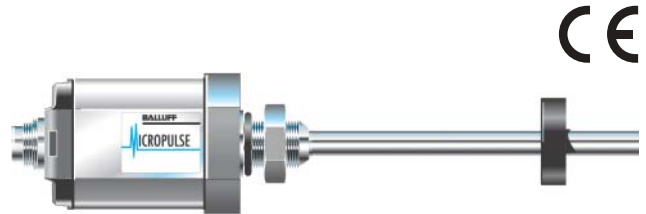
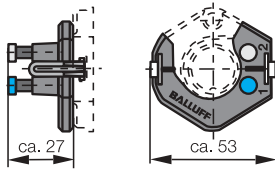

**Procedure for teach-in,
rising signal**

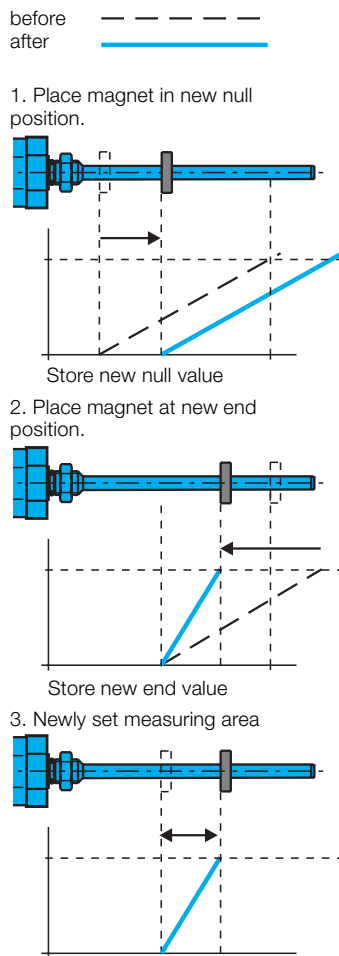

**Features of Micropulse
BTL5-A/C/E/G...B**

- 100 % adjustment of analog signal
- 3 calibration modes: Teach-in, adjustment for null and end point, and online setting
- Electronics head can be replaced if needed
- Short housing
- Error signal: No magnet in measuring area, transducer in calibration mode

Ordering code

Output voltage
Output current
Load current
Max. ripple
Load resistance
System resolution

Hysteresis
Repeatability
Internal sampling frequency
max. non-linearity

Temperature coefficient	Voltage output
	Current output

Operating voltage
Current draw
Polarity reversal protected
Overvoltage protection
Dielectric constant
Operating temperature
Storage temperature

Pin assignments	Pin	Color
Output signals	1	YE
	2	GY
	3	PK
	5	GN
Operating voltage	6	BU
	7	BN
	8	WH

Connect shield to housing.

Online setting

This programming function allows you to set the null and end point while in run mode, such as in a closed loop configuration. During the calibration procedure no error signal is output, so that no uncontrolled movement of the hydraulics can occur. The calibration range is limited to $\pm 12.5\%$.

- Included:
 - Transducer
 - Jam nut
 - Calibration device 112774
 - User's guide

Please order separately:
Magnets page **B.14**
Connectors starting page **BKS.3**

100 % stroke adjustment

Micropulse Transducers

Analog interface Rod series

BTL5 Rod analog A analog	BTL5 Rod analog E analog	BTL5 Rod analog C analog	BTL5 Rod analog G analog		
BTL5- A11 -M____-B-____	BTL5- E1 -M____-B-____	BTL5- C1 -M____-B-____	BTL5- G11 -M____-B-____		
0...10 V and 10...0 V	4...20 mA or 20...4 mA	0...20 mA or 20...0 mA	-10...10 V and 10...-10 V		
max. 5 mA ≤ 5 mV	≤ 500 Ohms ≤ 0.66 μA	≤ 500 Ohms ≤ 0.66 μA	max. 5 mA ≤ 5 mV		
≤ 0.33 mV			≤ 0.33 mV		
≤ 5 μm					
System resolution/min. 2 μm					
f _{STANDARD} = 2 kHz					
±100 μm to 500 mm nominal stroke					
±0.02 % 500...4000 mm nominal stroke					
[150 μV/°C + (5 ppm/°C × P × U/L)] × ΔT					
[0.6 μA/°C + (10 ppm/°C × P × I/L)] × ΔT					
24 V DC ±20 %					
≤ 150 mA					
yes					
Transzorb protection diodes					
500 V (Ground to housing)					
-40...+85 °C					
-40...+100 °C					
BTL5- A11 ...	BTL5- E10 ...	BTL5- E17 ...	BTL5- C10 ...	BTL5- C17 ...	BTL5- G11 ...
0 V Output	4...20 mA	20...4 mA	0...20 mA	20...0 mA	0 V Output
10...0 V					0 V Output
0...10 V					10...-10 V
GND	GND	GND	GND	GND	-10 ... 10V
+24 V DC	+24 V DC	+24 V DC	+24 V DC	+24 V DC	GND
(GND)	(GND)	(GND)	(GND)	(GND)	+24 V DC
					(GND)

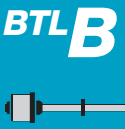

General data

Analog interface

Digital pulse interface

SSD interface

CANopen interface

PROFIBUS-DP interface

Magnets and floats

Installation notes

Special series

BKS



Page BKS.3

► Please enter code for output signal, nominal stroke and connection type in ordering code!

► Preferred models
Interfaces A11 and E10
BTL5-A11-M____-B-S 32,
BTL5-E10-M____-B-S 32
marked in blue are available from stock.

Ordering example:

BTL5-E1-M____-B-____

Output signal

- 1 rising and falling (for A and G)
- 0 rising
- 7 falling (for C and E)

Standard nominal strokes [mm]

0025, 0050, 0075, 0100, 0125, 0150, 0175, 0200, 0225, 0250, 0275, 0300, 0325, 0350, 0375, 0400, 0425, 0450, 0475, 0500, 0550, 0600, 0650, 0700, 0750, 0800, 0850, 0900, 0950, 1000, 1100, 1200, 1300, 1400, 1500, 1600, 1700, 1800, 1900, 2000, 2250, 2500, 2750, 3000, 3250, 3500, 3750, 3850, 4000 or in 5-mm increments on request.

Connection type

- S 32 Connector
- KA02 PUR cable 2 m
- KA05 PUR cable 5 m
- KA10 PUR cable 10 m
- KA15 PUR cable 15 m

P-Interface

Compatible with BTA processors and various OEM controls, e. g., Siemens, Schleicher, B & R, Bosch, Mitsubishi, Schiele, Parker, Esitron, Philips, WAGO and others.
Reliable signal transmission, even over cable lengths up to 500 m between BTA and BTL, is assured by the especially noise-immune RS485 differential drivers and receivers. Noise signals are effectively suppressed.

M-Interface

The I- and M-interfaces are control-specific interface variations.

I-Interface

Used for parallel operation of multiple transducers, for example up to 4 transducers can be operated by a single BTA-M/PMT card (see starting Page **BTA.2**).

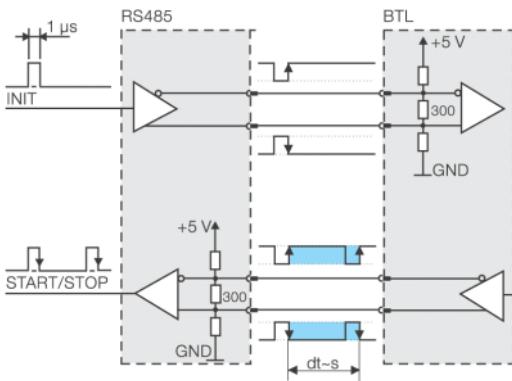

Block diagram for P-interface

Highly precise digitizing of the P-interface signal

Companies developing their own control and processing electronics can create a highly accurate P-interface cost effectively and with a minimum of effort using the Balluff digitizing chip. The digitizing chip was developed as a high-resolution, configurable ASIC for the Micropulse P-interface.

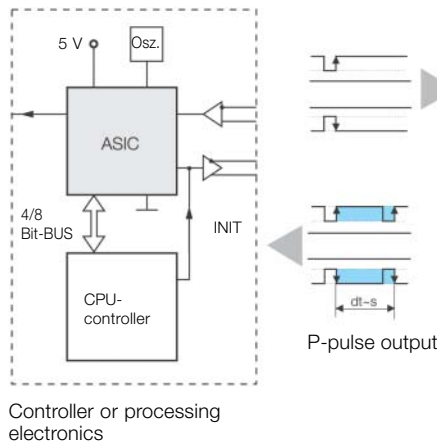
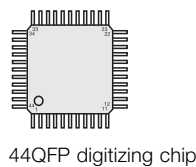

Series
Transducer interface
Input interface



Ordering code
System resolution
Repeatability
Resolution
Hysteresis
Internal sampling frequency
max. non-linearity
Temperature coefficient of overall system
Operating voltage
Current draw
Operating temperature
Storage temperature

Pin assignments	Pin	Color
In-/Output signals	Input	1 YE
	Output	2 GY
	Input	3 PK
	Output	5 GN
Operating voltage	6	BU
	7	BN
	8	WH

Connect shield to housing.

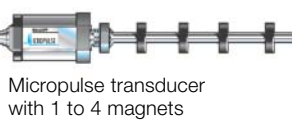

Benefits

- High resolution: the 1 µm actual resolution of the BTL transducer is fully supported by the 5 µm resolution of the chip (at low clock frequency 2 or 20 MHz)
- Position data from 4 magnets can be processed simultaneously
- 4/8-bit processor interface



ASIC INFO: +49 (0) 71 58/1 73-2 41

BTL5 Rod	BTL5 Rod	BTL5 Rod
Pulse P Pulse P	Impuls M Impuls M	Pulse I Pulse I
BTL5- P1 -M___-B-___	BTL5- M1 -M___-B-___	BTL5- I1 -M___-B-___

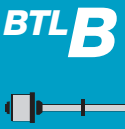

General data

Analog interface

Digital pulse interface

SSD interface

CANopen interface

PROFIBUS-DP interface

Magnets and floats

Installation notes

Special series

processing-dependent
 2 µm or ±1 digit depending on processing electronics
 ≤ 2 µm
 ≤ 4 µm
 $f_{\text{STANDARD}} = 1 \text{ kHz} = \leq 1400 \text{ mm}$
 ±100 µm to 500 mm nominal stroke
 ±0.02 % 500...3850 mm nominal stroke
 (6 µm + 5 ppm × L)/°C
 24 V DC ±20 %
 ≤ 100 mA
 -40...+85 °C
 -40...+100 °C

BTL5- P1 -M...	BTL5- M1 -M...	BTL5- I1 -M...
INIT	INIT	INIT
START/STOP	START/STOP	START/STOP
INIT	INIT	INIT
START/STOP	START/STOP	START/STOP
GND	GND	GND
+24 V DC (GND)	+24 V DC (GND)	+24 V DC (GND)

► Please enter code for nominal stroke and connection type in ordering code!

► Preferred P-interface models BTL5-P1-M___-B-S 32 marked in blue are available from stock.

► Included:
 - Transducer
 - Jam nut
 - User's manual

Please order separately:
 Magnets page **B.14**
 Connectors starting page **BKS.3**

Ordering example:

BTL5-P1-M___-B-___

Standard nominal strokes [mm]

0025, 0050, 0075, 0100, 0125, 0150, 0175, 0200, 0225, 0250, 0275, 0300, 0325, 0350, 0375, 0400, 0425, 0450, 0475, 0500, 0550, 0600, 0650, 0700, 0750, 0800, 0850, 0900, 0950, 1000, 1100, 1200, 1300, 1400, 1500, 1600, 1700, 1800, 1900, 2000, 2250, 2500, 2750, 3000, 3250, 3500, 3750, 3850, 4000 or in 5 mm increments on request.

Connection type

S 32 Connector
 KA02 PUR cable 2 m
 KA05 PUR cable 5 m
 KA10 PUR cable 10 m
 KA15 PUR cable 15 m



Page **BKS.3**



Page **BTA.3**

SSD Interface

Synchronous serial data transmission for controls made by Siemens, Schleicher, B & R, PEES, Schiele, Parker, Esitron etc. as well as for Balluff BDD-AM 10-...-1-SSD and BDD-CC 08-1-SSD display/controllers.

Reliable signal transmission, even over cable lengths of up to 400 m between control and BTL transducer is assured by especially noise-immune RS485/422 differential line drivers and receivers. Any noise signals are effectively suppressed.

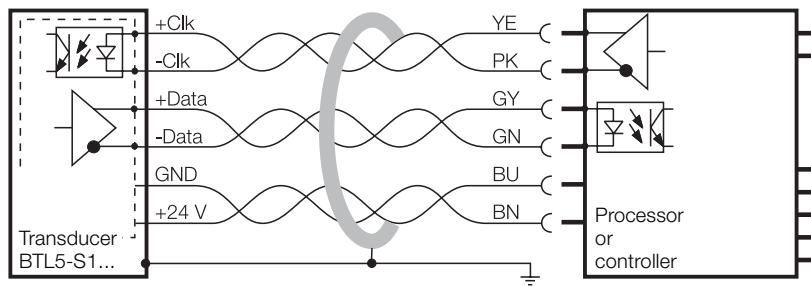

BTL5-S1... with processor/controller, wiring example

Clock frequency depends on cable length

Cable length	Clock freq.
< 25 m	< 1000 kHz
< 50 m	< 500 kHz
< 100 m	< 400 kHz
< 200 m	< 200 kHz
< 400 m	< 100 kHz

Super-fast 2 kHz Sampling rate

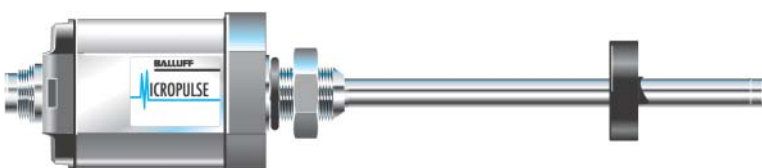

Series	BTL5 Rod
Output signal	synchronous serial
Transducer interface	S
Input interface	synchronous serial

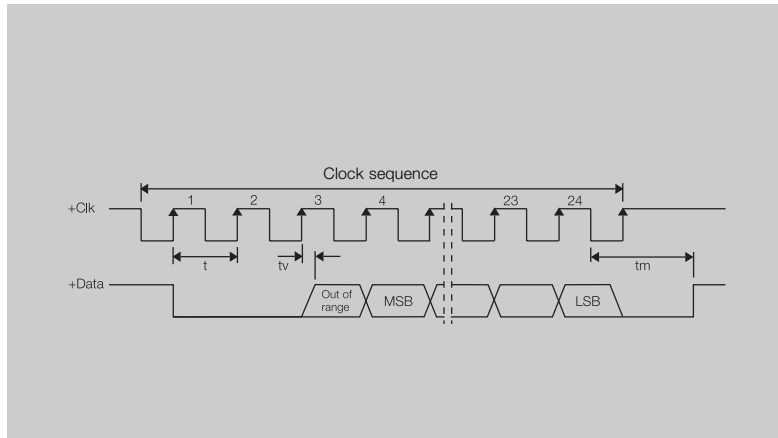

Ordering code	BTL5-S1__-M__-B-S 32
---------------	-----------------------------

Repeatability	±1 digit
System resolution depends on version (LSB)	1, 5, 10, 20 or 40 µm
Hysteresis	≤ 1 digit
Internal sampling frequency	f _{STANDARD} = 2 kHz
max. non-linearity	±30 µm at 5 und 10 µm resolution or ≤ ±2 LSB
Temperature coefficient of overall system	(6 µm + 5 ppm × L) / °C
Operating voltage	24 V DC ±20 %
Current draw	≤ 80 mA
Operating temperature	-40...+85 °C
Storage temperature	-40...+100 °C

Pin assignments	Pin	Color	
Control and data signals	1	YE	+Clk
	2	GY	+Data
	3	PK	-Clk
	5	GN	-Data
Supply voltage (external)	6	BU	GND
	7	BN	+24 V DC
	8	WH	must remain unconnected

► Please enter code for coding, system resolution, nominal stroke and connection type in ordering code!

Ordering example:

BTL5-S1 -M -B-

Coding	System Resolution	Standard nominal strokes [mm]	Connection type
0 Binary code rising (24 bits)	1 1 µm	0025, 0050, 0075, 0100,	S 32 Connector
1 Gray code rising (24 bits)	2 5 µm	0125, 0150, 0175, 0200,	KA02 PUR cable 2 m
6 Binary code rising (25 bits)	3 10 µm	0225, 0250, 0275, 0300,	KA05 PUR cable 5 m
7 Gray code rising (25 bits)	4 20 µm	0325, 0350, 0375, 0400,	KA10 PUR cable 10 m
	5 40 µm	0425, 0450, 0475, 0500,	KA15 PUR cable 15 m
		0550, 0600, 0650, 0700,	
		0750, 0800, 0850, 0900,	
		0950, 1000, 1100, 1200,	
		1300, 1400, 1500, 1600,	
		1700, 1800, 1900, 2000,	
		2250, 2500, 2750, 3000,	
		3250, 3500, 3750, 3850,	
		4000 or in 5 mm increments on request.	

► Included:
 - Transducer
 - User's guide

Please order separately:
 Magnets page **B.14**
 Floats page **B.15**
 Connectors starting page **BKS.3**

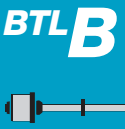

General data
 Analog interface
 Digital pulse interface
SSD interface
 CANopen interface
 PROFIBUS-DP interface
 Magnets and floats
 Installation notes
 Special series



Page **BKS.3**

CANopen Draft Standard 406 (Encoder Profile)

CANopen interface

Based on CAN (ISO/IEC 7498 and DIN ISO 11898), CANopen provides a Layer-7 implementation for industrial CAN networks. The serial data protocol of the CAN specification is defined according to the producer-consumer principle as opposed to most other fieldbus protocols. This eliminates target addressing of the process data. Each bus station decides for itself how the received data are processed.

The CANopen interface of the Micropulse transducer is compatible with CANopen conforming with CiA Standard DS301 Rev. 3.0, and with CAL and Layer 2 CAN networks.

CAN-BUS features

- Line topology, star structure also possible using repeaters
- Cost-effective 2-wire cabling
- Fast response times, high data integrity using CRC, hamming distance of 6
- Potential-free data transmission (RS485)
- 1 Mbps at cable lengths < 25 m
- Number of stations protocol-limited to 127

CANopen offers a high level of flexibility with respect to functionality and data exchange. Using a standard data sheet in the form of an EDS file it is easy to link the Micropulse transducers to any CANopen system.

Process Data Object (PDO)

Micropulse transducers send their position information optionally in one or two PDOs with 8 bytes of data each. The contents of the PDOs is free configurable. The following information can be sent:

- Current magnet position with resolution in 5 µm steps
- Current velocity of the magnet with resolution selectable in 0.1mm/s steps
- Current status of the four freely programmable cams.

Synchronisation Object (SYNC)

Serves as a net-wide trigger for synchronizing all network participants. When the SYNC object is received, all Micropulse transducers active on the bus store their current position and velocity information and then send it sequentially to the control. This assures time-synchronous capture of the measured values.

Emergency Object

This object is sent with the highest priority. This is used for example for error messages when cam states change.

Service Data Object (SDO)

Service Data Objects transmit the parameters for the transducer configuration. The transducer configuration may be carried out on the bus by the controller, or offline using a PC with a configuration tool which runs under Windows. The configuration is stored in the transducer in a non-volatile memory.



CiA 199911-301v30/11-009

CANopen system structures

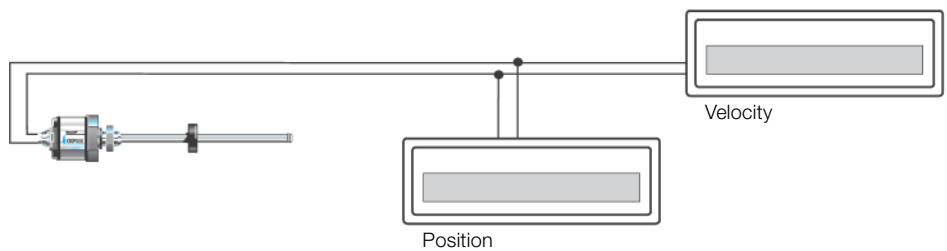
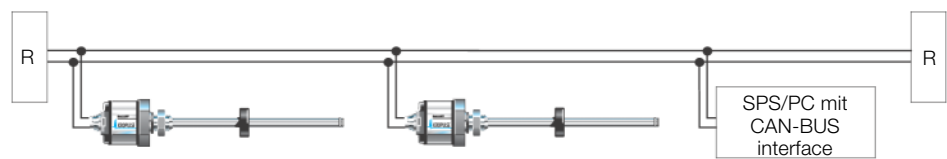

Simple CANopen-System including position and velocity display



Series	BTL5 Rod
Output signal	CANopen
Transducer interface	H
Input interface	CANopen

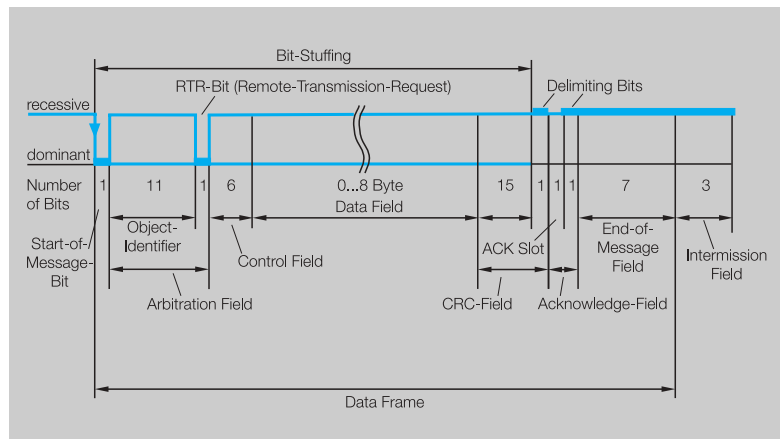

Ordering code	BTL5-H1__-M__-B-S 92
---------------	-----------------------------

CANopen interface	potential-free
Repeatability	±1 digit
System resolution	5 µm increments
configurable	Velocity
Hysteresis	≤ 1 Digit
Internal sampling frequency	f _{STANDARD} = 1 kHz
max. non-linearity	±30 µm at 5 µm resolution
Temperature coefficient of overall system	(6 µm +5 ppm × L)/°C
Operating voltage	24 V DC ±20 %
Current draw	≤ 100 mA
Operating temperature	-40...+85 °C
Storage temperature	-40...+100 °C

Cable length [m] per CiA DS301	< 25	< 50	< 100	< 250	< 500	< 1000	< 1250	< 2500
Baud rate [kBaud] per CiA DS301	1000	800	500	250	125	100	50	20/10

Pin assignments	Pin	Color
Control and data signals	1	WH
	2	BN
	3	BU
	4	GY
	5	GN

Using the CANopen interface and cable lengths up to 2500 m, the signal is sent at a length-dependent baud rate to the control. The high noise immunity of the connection is achieved using differential drivers and by the data monitoring scheme.

► Please enter code for software configuration, baud rate and nominal stroke when ordering! Cable upon request.

Ordering example:
BTL5-H1__-M__-B-S 92

Software configuration	Baud rate	Standard nominal strokes [mm]
1 1 × Position and 1 × velocity	0 1 MBaud	0025, 0050, 0075, 0100,
2 2 × Position and 2 × velocity	1 800 kBaud	0125, 0150, 0175, 0200,
3 4 × Position	2 500 kBaud	0225, 0250, 0275, 0300,
	3 250 kBaud	0325, 0350, 0375, 0400,
	4 125 kBaud	0425, 0450, 0475, 0500,
	5 100 kBaud	0550, 0600, 0650, 0700,
	6 50 kBaud	0750, 0800, 0850, 0900,
	7 20 kBaud	0950, 1000, 1100, 1200,
	8 10 kBaud	1300, 1400, 1500, 1600,
		1700, 1800, 1900, 2000,
		2250, 2500, 2750, 3000,
		3250, 3500, 3750, 3850,
		4000 or in 5 mm increments on request.

- Included:
- Transducer
 - Jam nut
 - Transducer user's guide
 - User's guide for configuration and CAN linking

Please order separately:
Magnets page **B.14**
Floats page **B.15**
Connectors starting page **BKS.4**

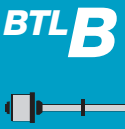

General data
Analog interface
Digital pulse interface
SSD interface
CANopen interface
PROFIBUS-DP interface
Magnets and floats
Installation notes
Special series



Page **BKS.4**

PROFIBUS-DP Standard EN 50170

As the market leading standard for serial data transmission for process automation, PROFIBUS-DP is the ideal choice for implementing automation tasks with cycle times of > 5 ms.

Data transmission

A PROFIBUS telegram can contain up to 244 bytes of user data per telegram and station. The BTL5-T uses max. 32 bytes (max. 4 position values and max. 4 velocity values) for process data transmission. Up to 126 active stations (Address 0...125) can be connected on PROFIBUS-DP. User data cannot be sent with station address 126. This address is used as the default address for bus stations that have to be parameterized by a Class 2 master (for setting the device address if there are no mechanical switches available). Each PROFIBUS station has the same priority. Prioritizing of individual stations is not intended, but can be done by the master since the bus transmission only makes up a fraction of the process cycle anyway. At a transmission rate of 12 Mbps, the transmission time for an average data telegram is in the 100 µs range.

Master

There are two types of possible masters for PROFIBUS-DP. Master Class 1 carries out the user data interchange with the connected slaves. Master Class 2 is intended for startup and diagnostic purposes and may be used to briefly assume control of a slave.

GSD (Device Master Data)

The length of the data exchangeable with a slave is defined in the Device Master Data file (GSD) and is checked by the slave with the configuration telegram and confirmed for correctness.

In modular systems, various configurations are defined in the GSD file. Depending on the desired functionality, one of these configurations can be selected by the user when the system is configured. The BTL5-T is a modular device with the possibility of selecting the number of magnets (position values).

Slave

Once a PROFIBUS master has received the parameter set defined for the slave, it is able to exchange data. The parameter set consists of slave parameters and configuration data. The parameter data contain the description of the slave settings (e.g. resolution of a position value). The configuration data describe the length and structure of the data telegram. For security reasons a slave is allowed to be written with new output data only by the master which previously parameterized and configured it. Only after the slave acknowledges both messages (parameter data and configuration data) can it be assumed that the configuration and function of the slave are known to the master.

Process data

Under PROFIBUS-DP the default is for process data to be sent from the master to slaves acyclically and for the slave data to then be queried. To ensure synchronization of multiple devices, the master may use the SYNC and FREEZE services.

After a RESET or after power is restored, the master attempts to establish contact with all the parameterized slaves in order of lowest to highest address. PROFIBUS-DP permits multiple Class 1 and Class 2 masters to be connected (see illustration below).

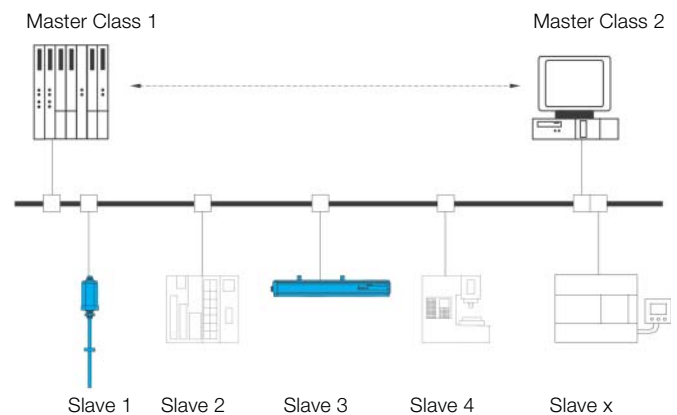

Device address DIP switch settable



Series	BTL5 Rod
Output signal	PROFIBUS-DP
Transducer interface	T
Input interface	PROFIBUS-DP

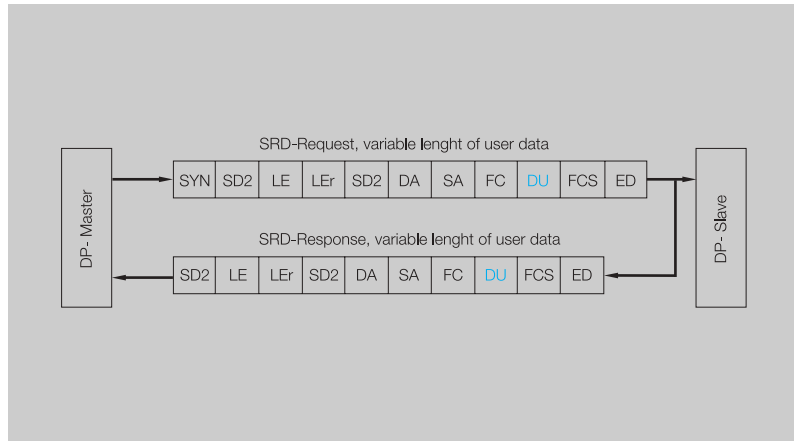

Ordering code	Connector version S103	BTL5-T1_0-M_-_-B-S103
---------------	------------------------	------------------------------

Profibus Version	EN 50170, Encoder				
Profibus interface	potential-free				
Repeatability	±1 digit				
System resolution	Position	5 µm increments (configurable)			
configurable	Velocity	0.1 mm/s increments (configurable)			
Hysteresis	≤ 1 digit				
Internal sampling frequency	f _{STANDARD} = 1 kHz				
max. non-linearity	±30 µm at 5 µm resolution				
Temperature coefficient of overall system	(6 µm + 5 ppm × L)/°C				
Magnet traverse speed	any				
Operating voltage	24 V DC ±20 %				
Current draw	≤ 120 mA				
Operating temperature	-20...+85 °C				
Storage temperature	-20...+100 °C				
GSD file	BTL504B2.GSD				
Address assignment	mechanical switches and Master Class 2				
Cable length [m]	< 100	< 200	< 400	< 1000	< 1200
Baud rate [Kbps]	12000	1500	900	187.5	93.7/19.2/9.6

Pin assignments	S103 5-pin	S103 3-pin
Control and data signals		
Data GND	3	
RxD/TxD-N (A)	2	
RxD/TxD-P (B)	4	
VP +5 V	1	
Supply voltage and shield		
+24 V		1
0 V (GND)		3
Ground PROFIBUS-DP	5	
Shield supply		4

► Please enter code for software configuration and nominal stroke in ordering code!

► Included:
 – Transducer
 – User's guide

Please order separately:
 Magnets starting page **B.14**
 Connectors starting page **BKS.6**
 GSD file BTL5TGSD 119399 (free of charge)

Ordering example:
BTL5-T1_0-M_-_-B-S103

Software configuration	Standard nominal strokes [mm]
1 1 magnet	0025, 0050, 0075, 0100, 0125,
2 2 magnets	0150, 0175, 0200, 0225, 0250,
3 4 magnets	0275, 0300, 0325, 0350, 0375,
	0400, 0425, 0450, 0475, 0500,
	0550, 0600, 0650, 0700, 0750,
	0800, 0850, 0900, 0950, 1000,
	1100, 1200, 1300, 1400, 1500,
	1600, 1700, 1800, 1900, 2000,
	2250, 2500, 2750, 3000, 3250,
	3500, 3750, 3850 or in 5 mm increments on request.

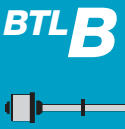

General data
 Analog interface
 Digital pulse interface
 SSD interface
 CANopen interface
PROFIBUS-DP interface
 Magnets and floats
 Installation
 Special series



Description for series	Magnet BTL5 Rod	Magnet BTL5 Rod	Magnet BTL5 Rod	Magnet BTL5 Rod
------------------------	---------------------------	---------------------------	---------------------------	---------------------------

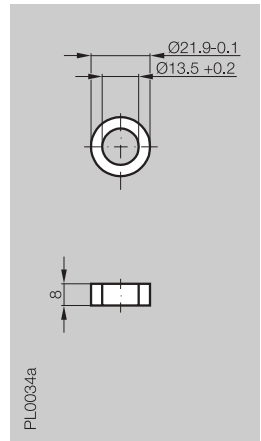
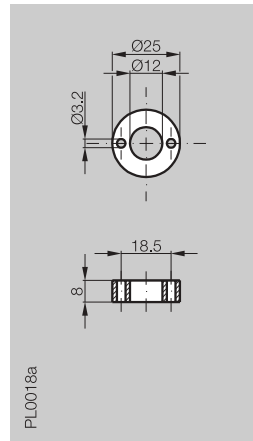
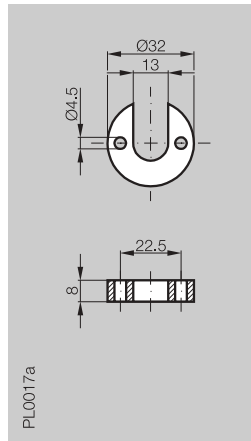
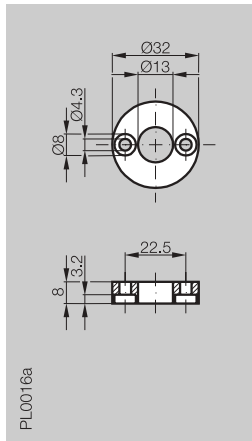

Ordering code Al	BTL-P-1013-4R	BTL-P-1013-4S	BTL-P-1012-4R	BTL-P-1014-2R
Material	Al	Al	Al	Al
Weight	approx. 12 g	approx. 12 g	approx. 12 g	approx. 10 g
Magnet traverse speed	any	any	any	any
Operating temperature/Storage temperature	-40...+100 °C	-40...+100 °C	-40...+100 °C	-40...+100 °C
Ordering code PA 60 glass fiber reinforced	BTL-P-1013-4R-PA		BTL-P-1012-4R-PA	
Material	PA 60 glass fiber reinforced		PA 60 glass fiber reinforced	
Weight	approx. 10 g		approx. 10 g	
Magnet traverse speed	any		any	
Operating temperature/Storage temperature	-40...+100 °C		-40...+100 °C	



Description for series	Float BTL5 Rod	Float BTL5 Rod	Float BTL5 Rod	Float BTL5 Rod
------------------------	--------------------------	--------------------------	--------------------------	--------------------------

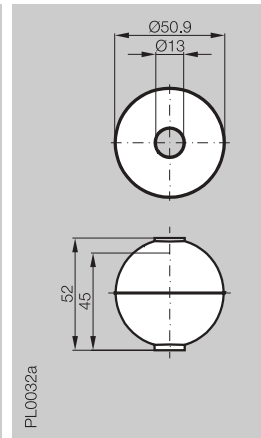
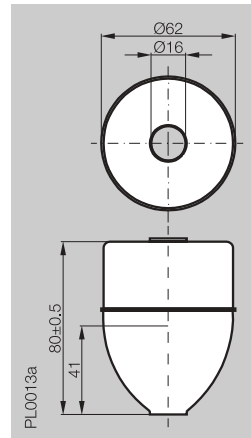
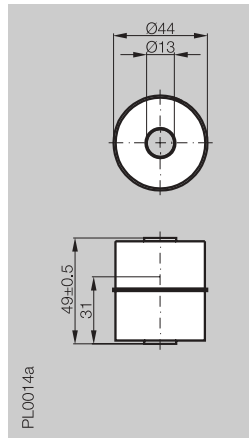
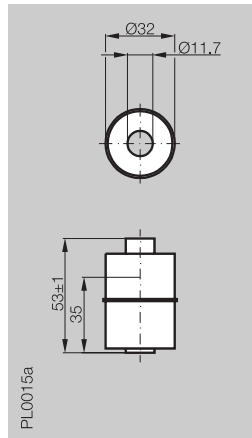

Ordering code	BTL2-S-3212-4Z	BTL2-S-4414-4Z	BTL2-S-6216-8P	BTL2-S-5113-4K
Material	Stainless 1.4571	Stainless 1.4571	Stainless 1.4541	Stainless 1.4571
Weight	approx. 20 g	approx. 35 g	approx. 66 g	approx. 34 g
Operating/Storage temperature	-40...+120 °C	-40...+120 °C	-40...+120 °C	-40...+120 °C
Displacement in water	approx. 35 mm	approx. 30 mm	approx. 41 mm	approx. 26 mm
Pressure resistance (static)	24 bar	20 bar	15 bar	40 bar

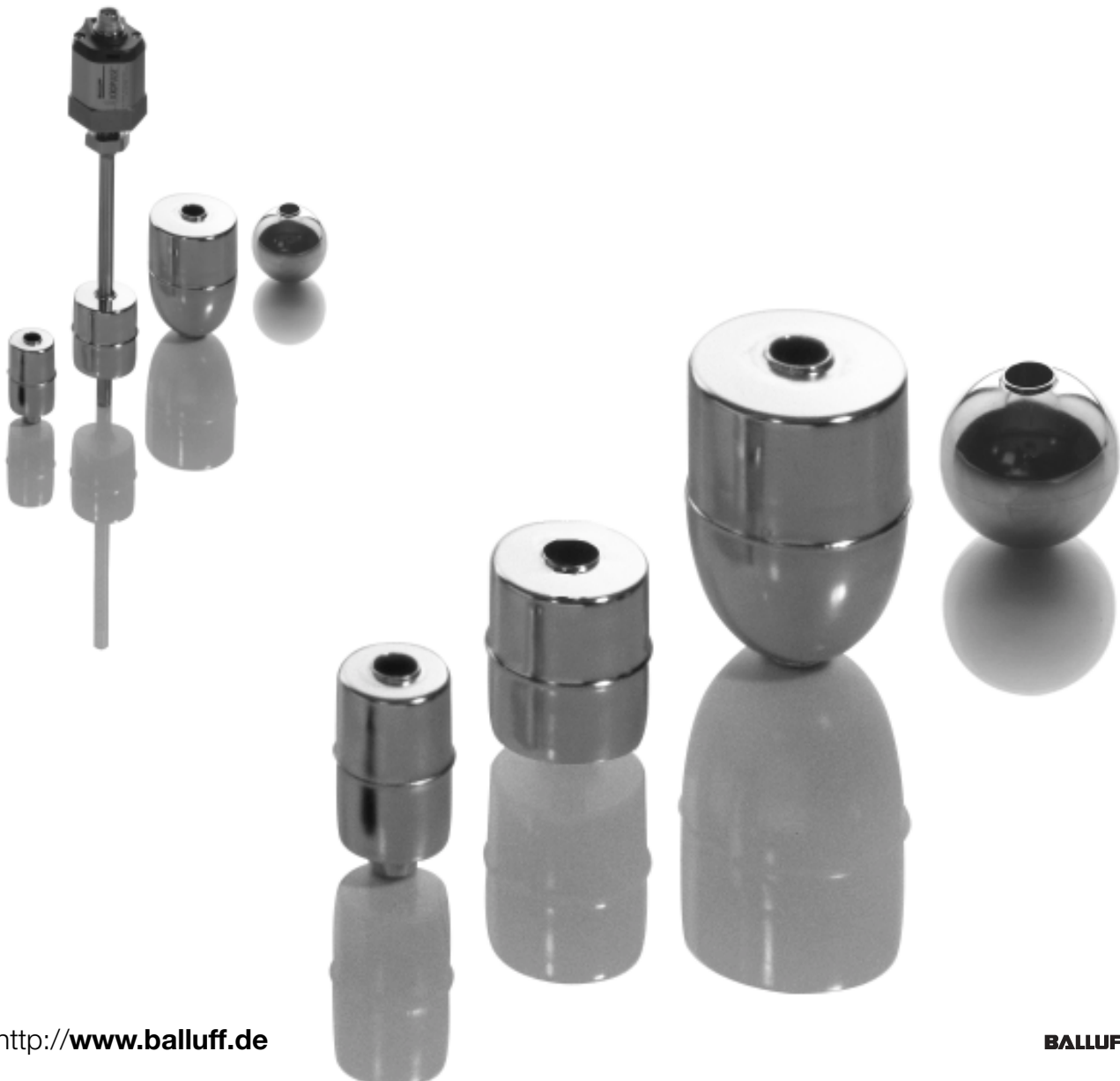

General data

Analog interface

Digital pulse interface

SSD interface

CANopen interface

PROFIBUS-DP interface

Magnets and floats

Installation notes

Special series

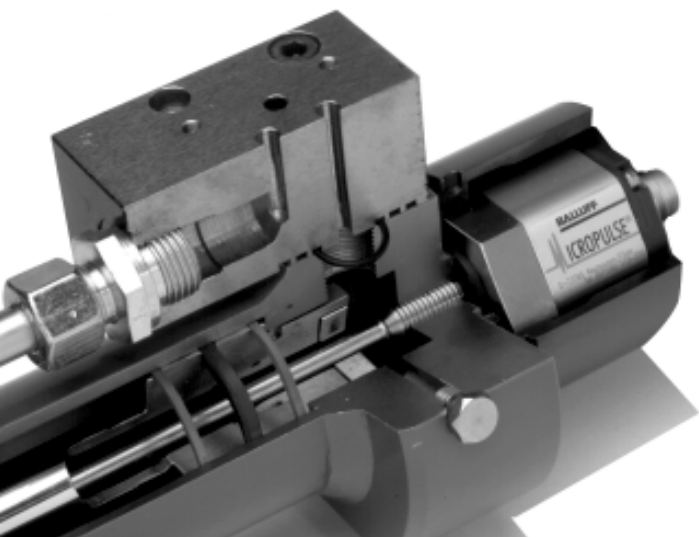
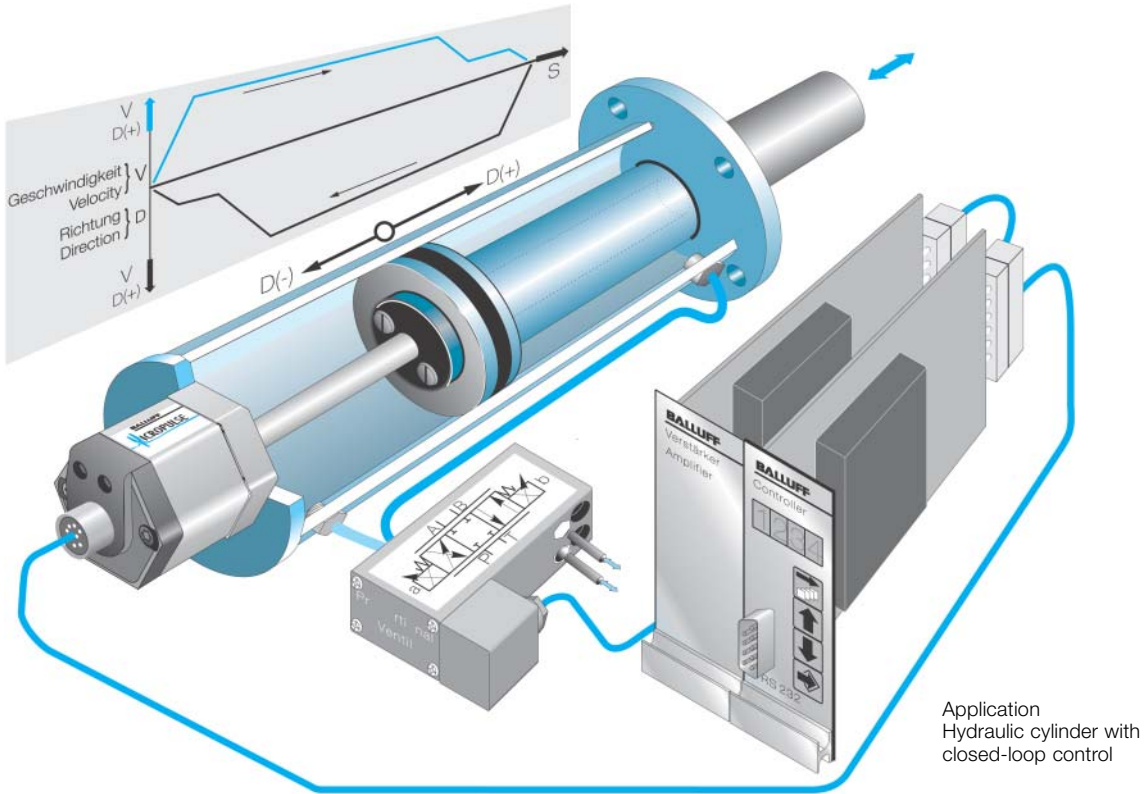

Installation in
hydraulic cylinders



Hassle-free service

Cylinder-mounted transducers are often located in difficult to access spots. If a transducer is damaged or fails, replacing the complete transducer with head and waveguide is often a difficult and expensive proposition. Should a problem occur in the electronics of the

Micropulse transducer, the electronics head can be easily and quickly exchanged for a new one. The fluid circuit also remains intact, with no draining necessary.

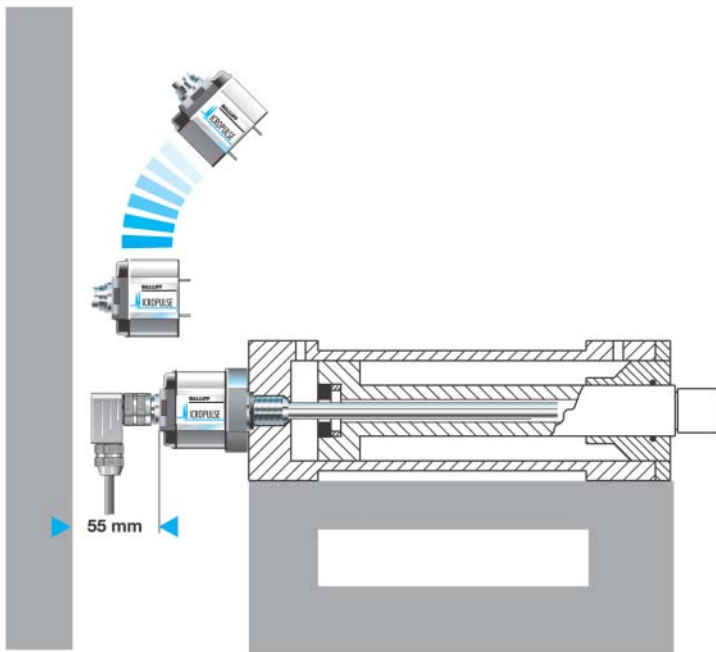

Servicing a horizontal installation

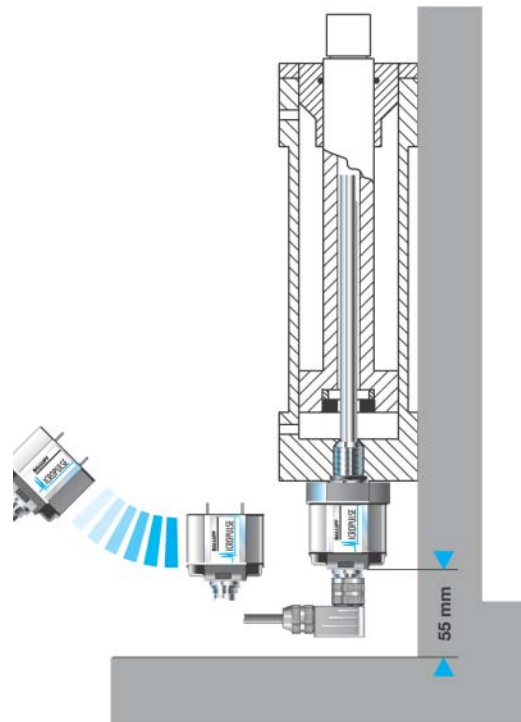

Servicing a vertical installation

Installation

The BTL Micropulse transducer is provided with an M18 x 1.5 mounting thread. We recommend mounting into non-magnetizable materials.

If magnetizable materials are used, the installation must be carried out as shown in the drawing below. Sealing is at the flange mounting surface, using the supplied O-ring 15.4 x 2.1 with the M18 x 1.5 thread..

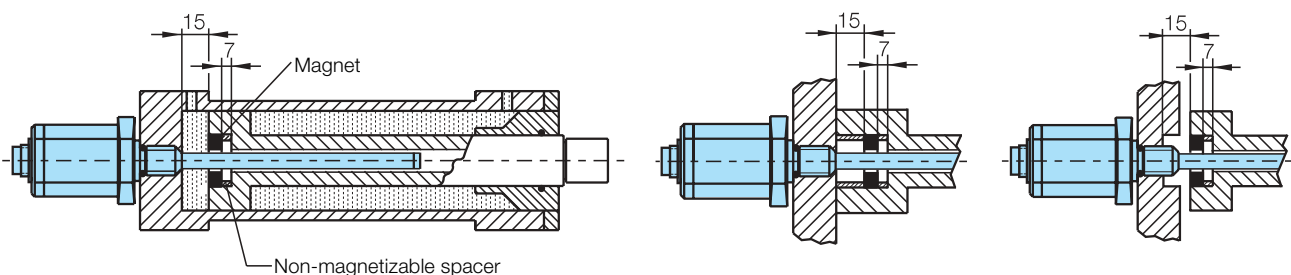
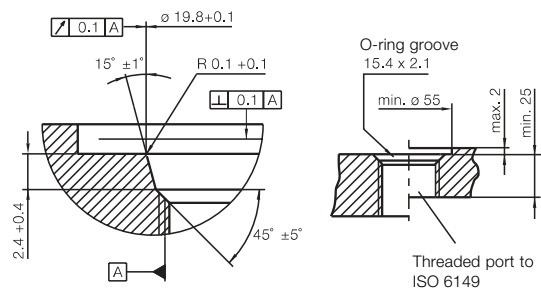

General data

Analog interface

Digital interface

SSD interface

CANopen interface

PROFIBUS-DP interface

Magnets and floats

Installation notes

Special series

**Micropulse
Special series**

Difficult applications often make special demands on the sensors. Balluff meets these requirements with transducers that have been specified and developed in conjunction with the systems integrator. Behind this is a large, highly motivated Micropulse development team as well as Balluff's own EMC Testing Laboratory and shock and vibration test centers.

The "3-in-1" transducer!

- 2- or 3-way redundant positioning system for heightened safety requirements
- One transducer consists of two or three completely separate positioning lines
- Start/Stop or analog interfaces
- Compact housing

Available outputs:

- analog 0...10 V, 4...20 mA, 0...20 mA, -10...10 V
- P-type pulse interface



Tilt control on rail cars



Propeller pitch control



Rudder control

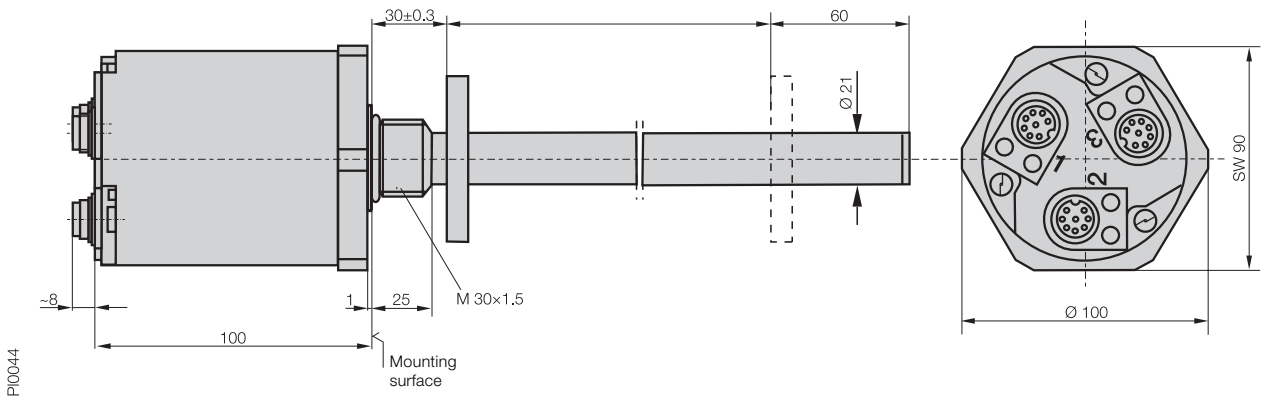

0...10 V
4...20 mA
0...20 mA
-10...10 V



BTLB



General data

Analog interface

Digital pulse interface

SSD interface

CANopen interface

PROFIBUS-DP interface

Magnets and floats

Installation notes

Special series

Special series

